

Eclipse RatioMatic

Burners

Model RM0100

Version 5

Parameter	Specification		
	Chamber Pressure "w.c. (mbar)	50 Hz	60 Hz
Blower Type			
Maximum Input, Btu/h (kW)¹	-2.0 (-5.0)	1,375,000 (403)	1,295,000 (379)
<i>Contact factory for chamber pressures outside the given range, or varying chamber pressure conditions.</i>	-1.0 (-2.5)	1,295,000 (379)	1,210,000 (354)
	0.0 (0.0)	1,210,000 (354)	1,120,000 (328)
	1.0 (2.5)	1,120,000 (328)	1,020,000 (298)
	2.0 (5.0)	1,020,000 (298)	915,000 (268)
Minimum Input On-Ratio, Btu/h (kW) <i>Lower inputs may be achieved. Contact factory.</i>	with high turndown ratio regulator	30,000 (9)	
	with standard ratio regulator	40,000 (12)	
Main Gas Inlet Pressure, "w.c. (mbar)² <i>Fuel pressure at ratio regulator inlet</i>	10 to 20 (25 to 50)		
High Fire Flame Length, inches (mm) <i>Measured from the outlet end of the combustor</i>	Natural Gas	32 (813)	
	Propane / Butane	38 (965)	
Maximum Chamber Temperature, °F (°C)	Alloy Tube	1500 (815)	
	SiC Tube	1900 (1038)	
Flame Detection	Flame rod or UV Scanner		
Fuel <i>For any other mixed gas, contact Eclipse, Inc.</i>	Natural Gas, Propane, Butane ³		
Blower Motor Power, Hp	0.5		
Weight, lbs (kg)⁴	88 (40)		
Approvals	 AN30		

¹ Maximum inputs for packaged blower versions are given for the standard combustion air blower without an inlet air filter.

² For proper performance, this pressure must be kept constant across the burner operating range.

³ See Design Guide 110 for more information about typical fuel composition and properties.

⁴ All weights are approximate.

- All information is based on laboratory testing. Different chamber conditions will affect the data.
- All inputs based upon gross calorific values and standard conditions; 1 atmosphere, 70°F (21°C).
- Eclipse reserves the right to change the construction and/or configuration of our products at any time without being obliged to adjust earlier supplies accordingly.

Performance Graphs

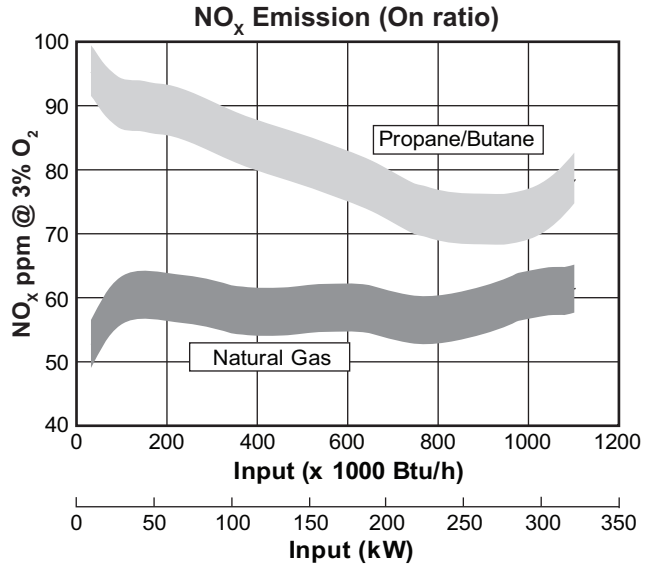
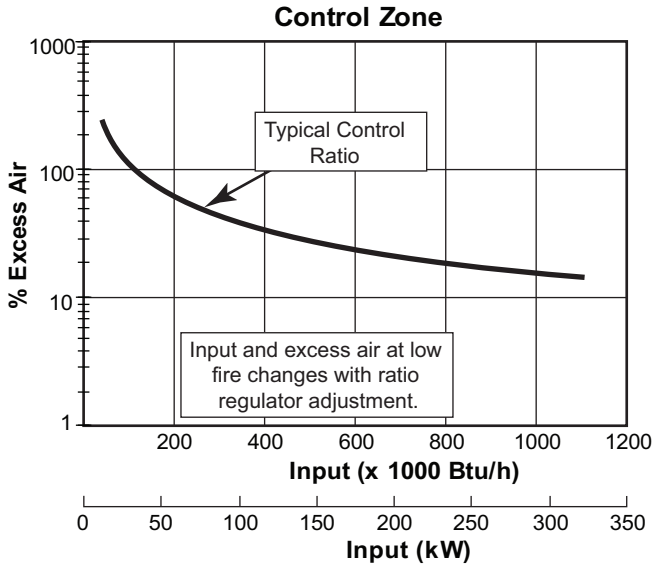

NO_x Emission data is given for:

- Ambient combustion air ~70°F (21°C)
- Less than 700°F (370°C) firing chamber
- Minimal process air velocity
- Low fire input adjusted to 40,000 Btu/h (12 kW)
- ppm volume, dry @ 3% O₂
- Neutral chamber pressure

Emissions from the burner are influenced by:

- Chamber conditions
- Fuel type
- Firing rate
- Ratio regulator adjustment
- Combustion air temperature

CO emission is largely influenced by chamber conditions. Contact your local Eclipse Combustion representative for an estimate of CO emission on your application

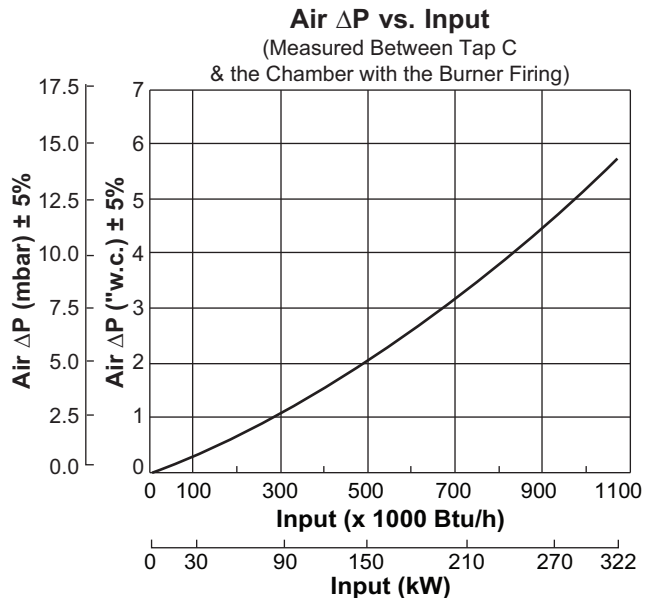
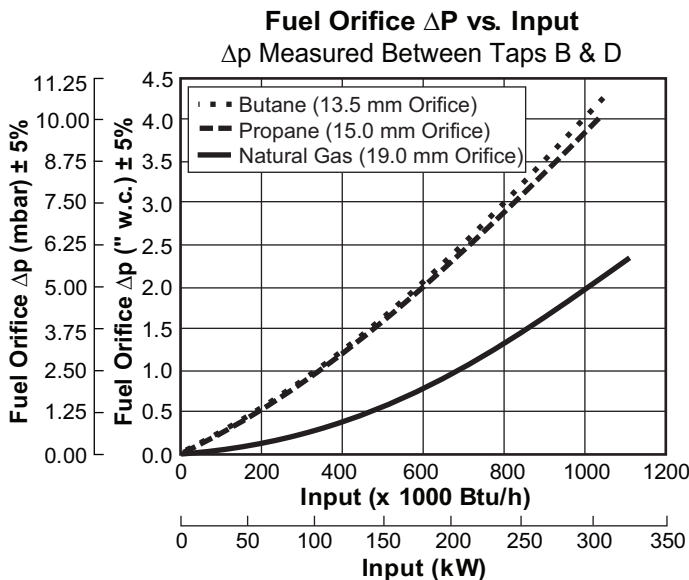

Dimensions and Specifications

Dimensions in mm (in)

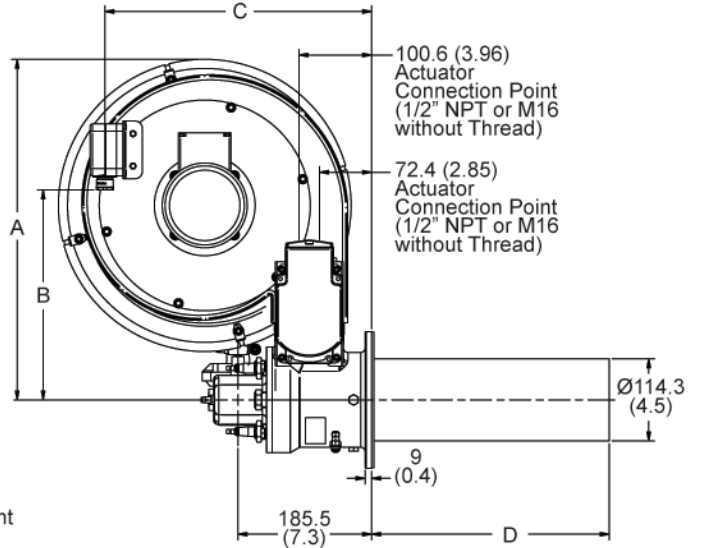
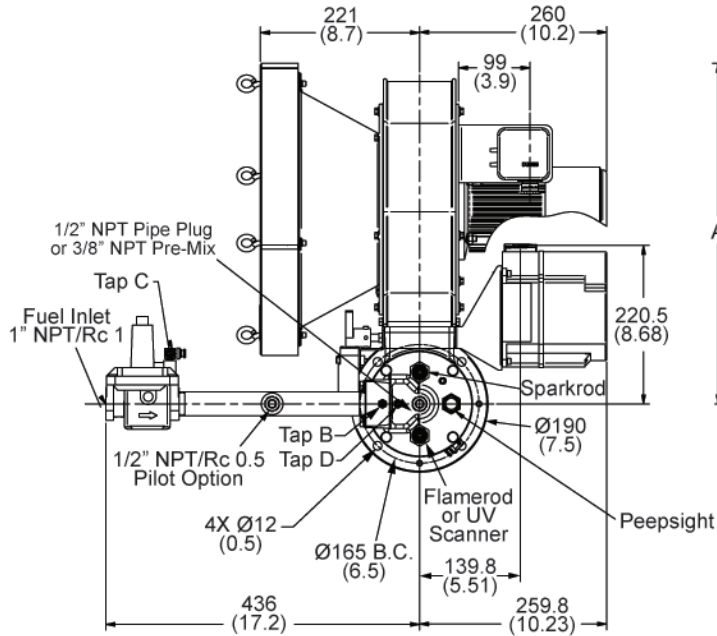

Shown with Alloy Combustor

Blower Size	A	B	C
50 Hz	534 (21.0)	384 (15.1)	310 (12.2)
60 Hz	481 (18.9)	342 (13.5)	320 (12.6)

Combustor Type	D
Straight Stainless Steel Alloy Tube	254 (10)
Straight Stainless Steel Alloy Tube	330 (13)
Straight Stainless Steel Alloy Tube	406 (16)

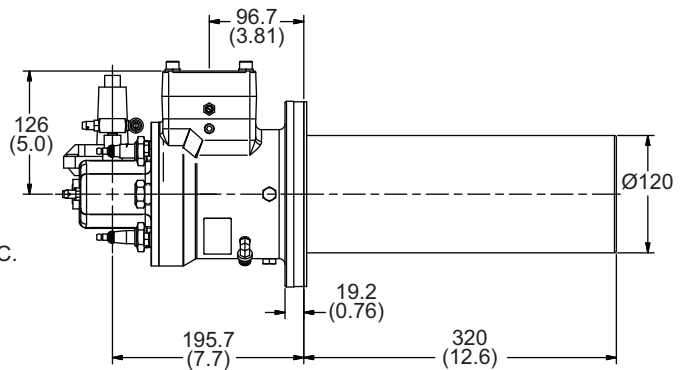
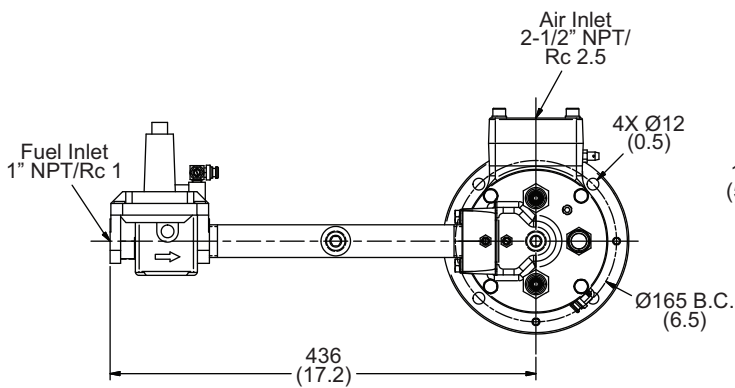

Shown with Silicon Carbide
Combustor and Flange

Combustor Options

Alloy Combustor

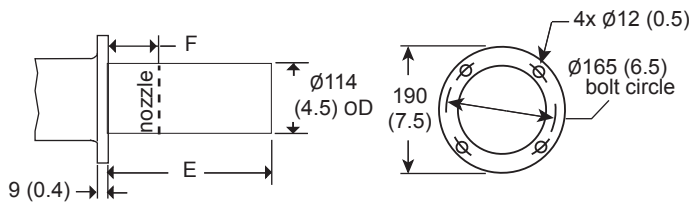

Silicon Carbide Combustor

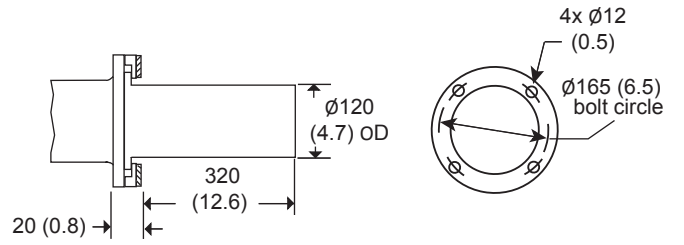

E	F
254 (10.0)	84 (3.3)
330 (13.0)	160 (6.3)
406 (16.0)	236 (9.3)

Burner Configurations

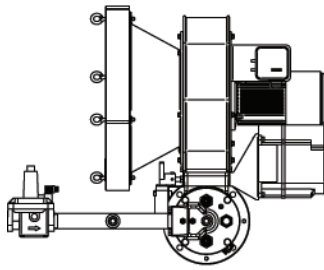

Upright Left Hand Piping

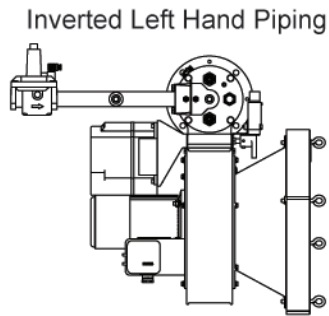

Inverted Left Hand Piping

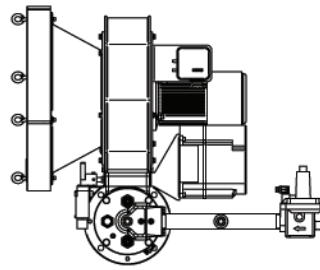

Upright Right Hand Piping

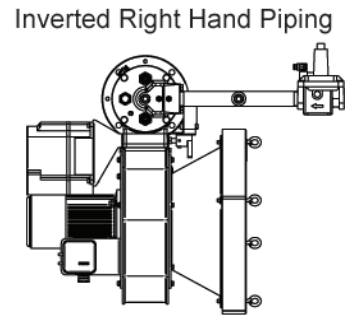

Inverted Right Hand Piping