

# Eclipse ThermJet Burners

## for Preheated Combustion Air

Model TJPCA0015

Version 2

Parameter			Specifications		
			Natural Gas	Propane	Butane
Maximum Input BTU/hr (kW)			150,000 (44)	150,000 (44)	150,000 (44)
Minimum Input, On-Ratio BTU/hr (kW)			15,000 (4.4)	15,000 (4.4)	15,000 (4.4)
Gas Inlet Pressure Required "w.c. (mbar) Fuel Pressure at Gas Inlet (Tap "B" - see page 3)	Combustion Air Temp	Ambient	7.5 (18.6)	7.5 (18.6)	7.5 (18.6)
		300°F (150°C)	9.8 (24.4)	9.8 (24.4)	9.8 (24.4)
		700°F (370°C)	14.0 (34.9)	14.0 (34.9)	14.0 (34.9)
		1000°F (540°C)	17.2 (42.7)	17.2 (42.7)	17.2 (42.7)
Air Inlet Pressure Required "w.c. (mbar) 15% Excess Air at Maximum Input (Tap "A" - see page 3)	Combustion Air Temp	Ambient	3.5 (8.7)	3.5 (8.7)	3.5 (8.7)
		300°F (150°C)	5 (12.5)	5 (12.5)	5 (12.5)
		700°F (370°C)	7.7 (19.2)	7.7 (19.2)	7.7 (19.2)
		1000°F (540°C)	9.6 (23.9)	9.6 (23.9)	9.6 (23.9)
High Fire Flame Length Inches (mm) (Measured from End of Combustor)			<11.0 (279)	<10.0 (254)	<11.0 (279)
Flame Detection			UV scanner available for all combustors.		
Fuel For any other mixed gas, contact Eclipse for orifice sizing.			Natural gas, propane, or butane		
Approvals					

- All information is based on laboratory testing in neutral (0.0" w.c.) pressure chamber. Different chamber size and conditions may affect the data.
- All information is based on standard combustor design. Changes in combustor will alter performance and pressures.
- All inputs based upon gross calorific values.
- Eclipse reserves the right to change the construction and/or configuration of our products at any time without being obliged to adjust earlier supplies accordingly.
- Plumbing of air and gas will affect accuracy of orifice readings. All information is based on generally acceptable air and gas piping practices.

## Performance Graphs

### Ignition & Operational Zones

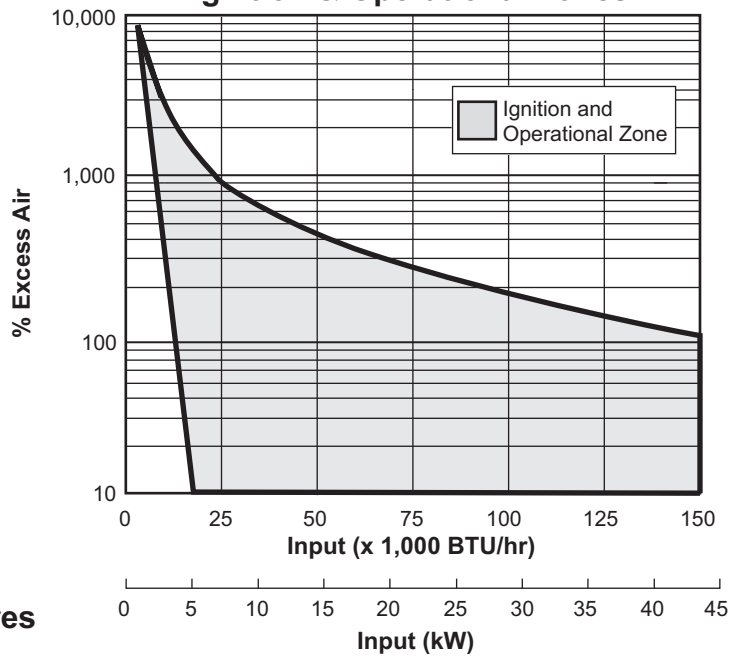

### NO<sub>x</sub> vs Preheated Air Temperatures (Based on Maximum Firing Rate)

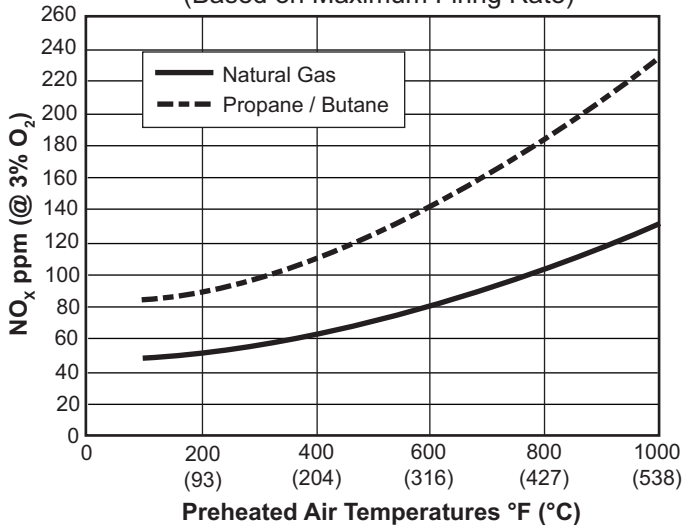

Emissions from the burner are influenced by:

- Fuel type
- Combustion air temperature
- Firing rate
- Chamber conditions
- Percent of excess air

For estimates of other emissions, contact Eclipse.

### Gas Orifice ΔP vs. Input (Measured from Tap B to Tap D)

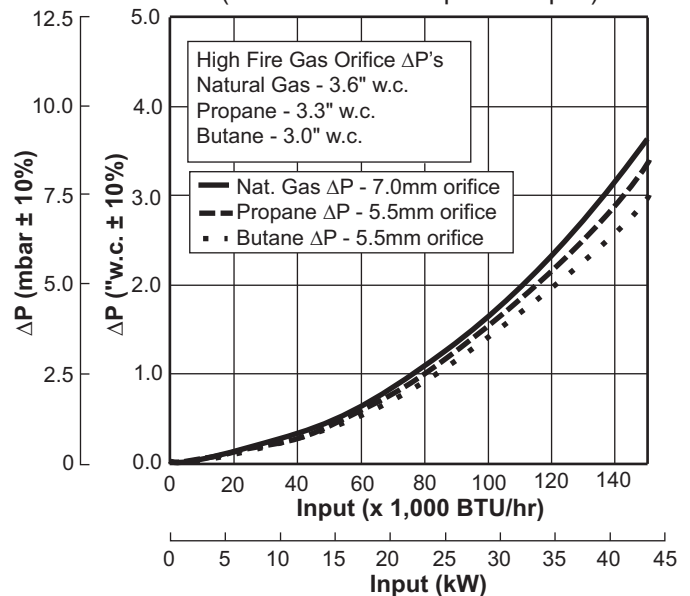

## Dimensions in inches (mm)

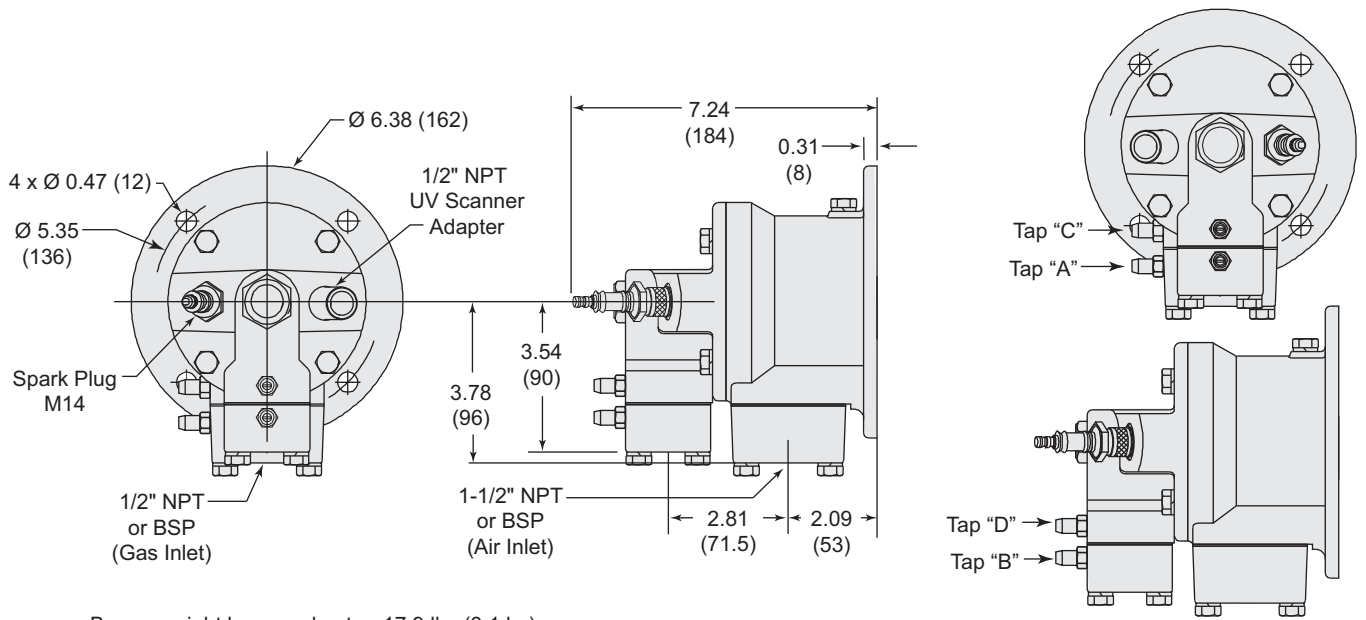

Burner weight less combustor: 17.9 lbs (8.1 kg)

### Combustor

Exhaust Outlet Diameter - Medium Velocity:  $\text{Ø } 1.26$  (32)

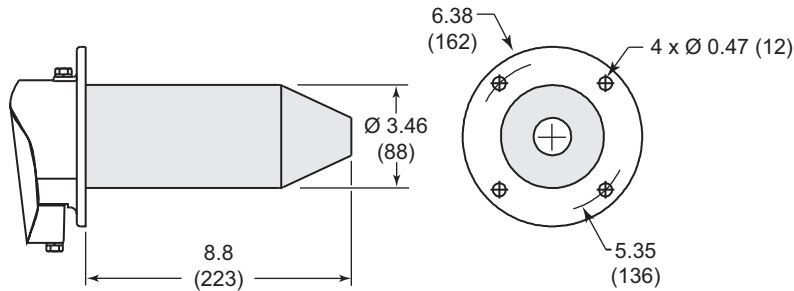

#### Alloy Tube (AISI 310)

Weight: 2.1 lbs (0.95 kg)  
 Max. Chamber Temp: 1,750°F (950°C)  
 (Not suitable for preheated air over 700°F)

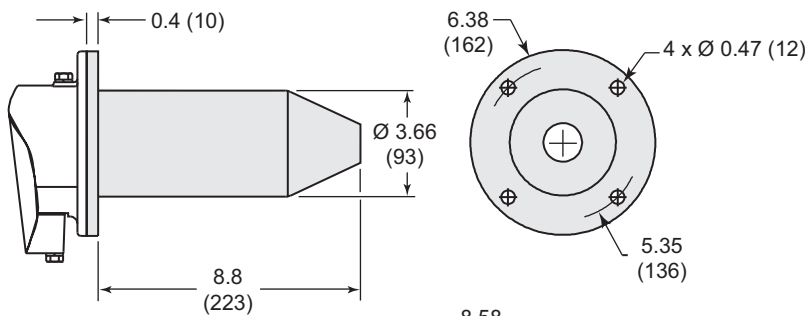

#### Silicon Carbide Tube

Weight: 3.6 lbs (1.63 kg)  
 Max. Chamber Temp: 2,200°F (1200°C)

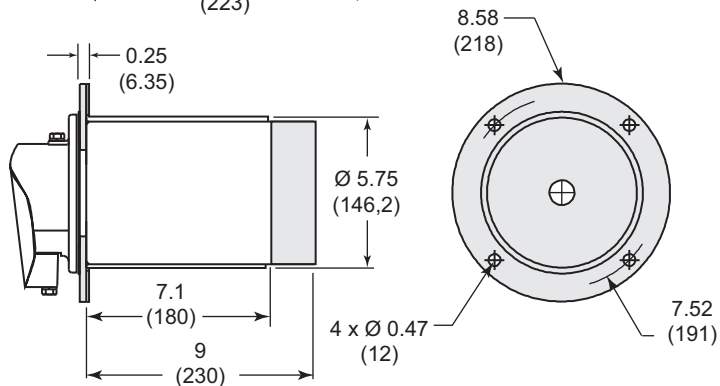

#### Refractory Block (w/330 SS wrapper)

Weight: 14 lbs (6.35 kg)  
 Max. Chamber Temp: 2,800°F (1538°C)

