

Eclipse ThermJet Burners

for Preheated Combustion Air

Model TJPCA0025

Version 2

Parameter			Specifications		
			Natural Gas	Propane	Butane
Maximum Input BTU/hr (kW)			250,000 (73)	250,000 (73)	250,000 (73)
Minimum Input, On-Ratio BTU/hr (kW)			25,000 (7.3)	25,000 (7.3)	25,000 (7.3)
Gas Inlet Pressure Required "w.c. (mbar) Fuel Pressure at Gas Inlet (Tap "B" - see page 3)	Combustion Air Temp	Ambient	6.8 (16.9)	7.4 (18.4)	7.0 (17.4)
		300°F (150°C)	8.8 (21.9)	9.4 (23.4)	9.0 (22.4)
		700°F (370°C)	12.5 (31.1)	31.1 (32.6)	12.7 (31.6)
		1000°F (540°C)	15.3 (38.0)	15.9 (39.5)	15.5 (38.5)
Air Inlet Pressure Required "w.c. (mbar) 15% Excess Air at Maximum Input (Tap "A" - see page 3)	Combustion Air Temp	Ambient	6.3 (15.7)	6.3 (15.7)	6.3 (15.7)
		300°F (150°C)	9.1 (22.7)	9.1 (22.7)	9.1 (22.7)
		700°F (370°C)	13.8 (34.4)	13.8 (34.4)	13.8 (34.4)
		1000°F (540°C)	17.4 (43.3)	17.4 (43.3)	17.4 (43.3)
High Fire Flame Length Inches (mm) (Measured from End of Combustor)			<14.0 (356)	<14.0 (356)	<14.0 (356)
Flame Detection			UV scanner available for all combustors.		
Fuel For any other mixed gas, contact Eclipse for orifice sizing.			Natural gas, propane, or butane		
Approvals					

- All information is based on laboratory testing in neutral (0.0" w.c.) pressure chamber. Different chamber size and conditions may affect the data.
- All information is based on standard combustor design. Changes in combustor will alter performance and pressures.
- All inputs based upon gross calorific values.
- Eclipse reserves the right to change the construction and/or configuration of our products at any time without being obliged to adjust earlier supplies accordingly.
- Plumbing of air and gas will affect accuracy of orifice readings. All information is based on generally acceptable air and gas piping practices.

Performance Graphs

Ignition & Operational Zones

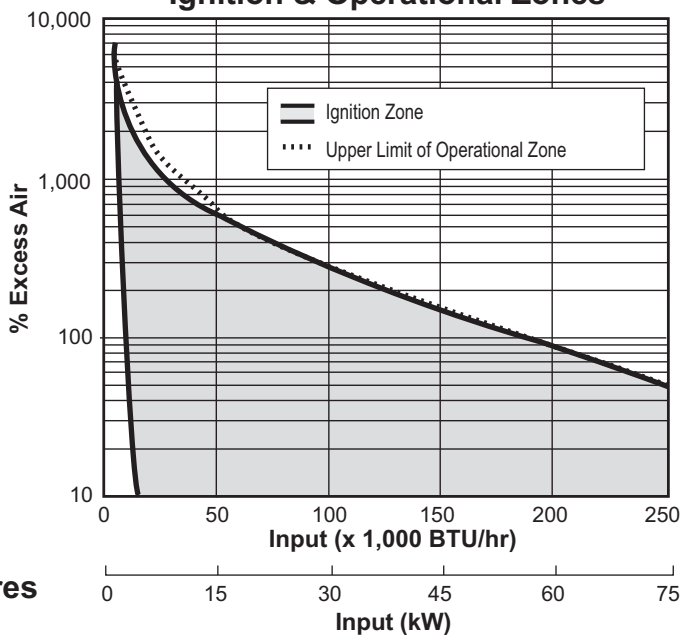

NO_x vs Preheated Air Temperatures (Based on Maximum Firing Rate)

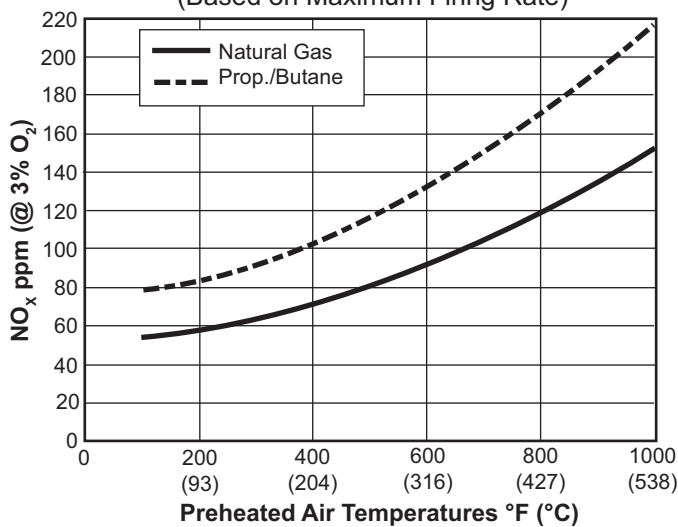

Emissions from the burner are influenced by:

- Fuel type
- Combustion air temperature
- Firing rate
- Chamber conditions
- Percent of excess air

For estimates of other emissions, contact Eclipse.

Gas Orifice ΔP vs. Input (Measured from Tap B to Tap D)

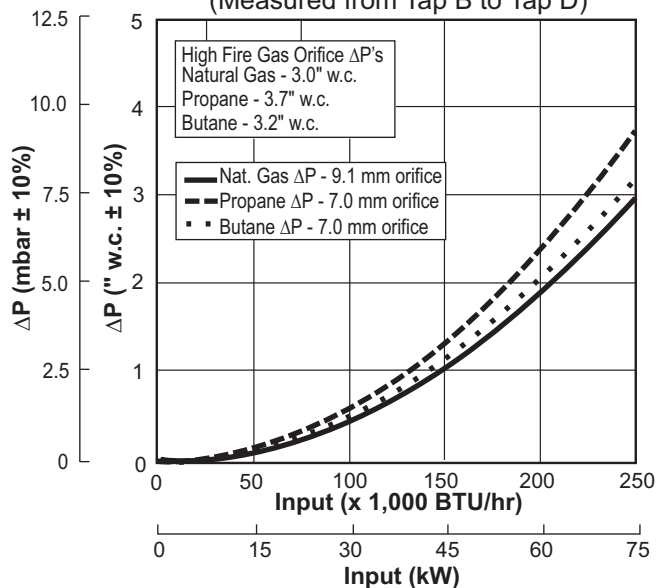

Dimensions in inches (mm)

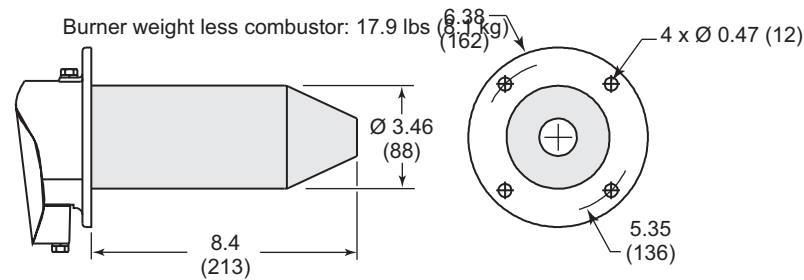
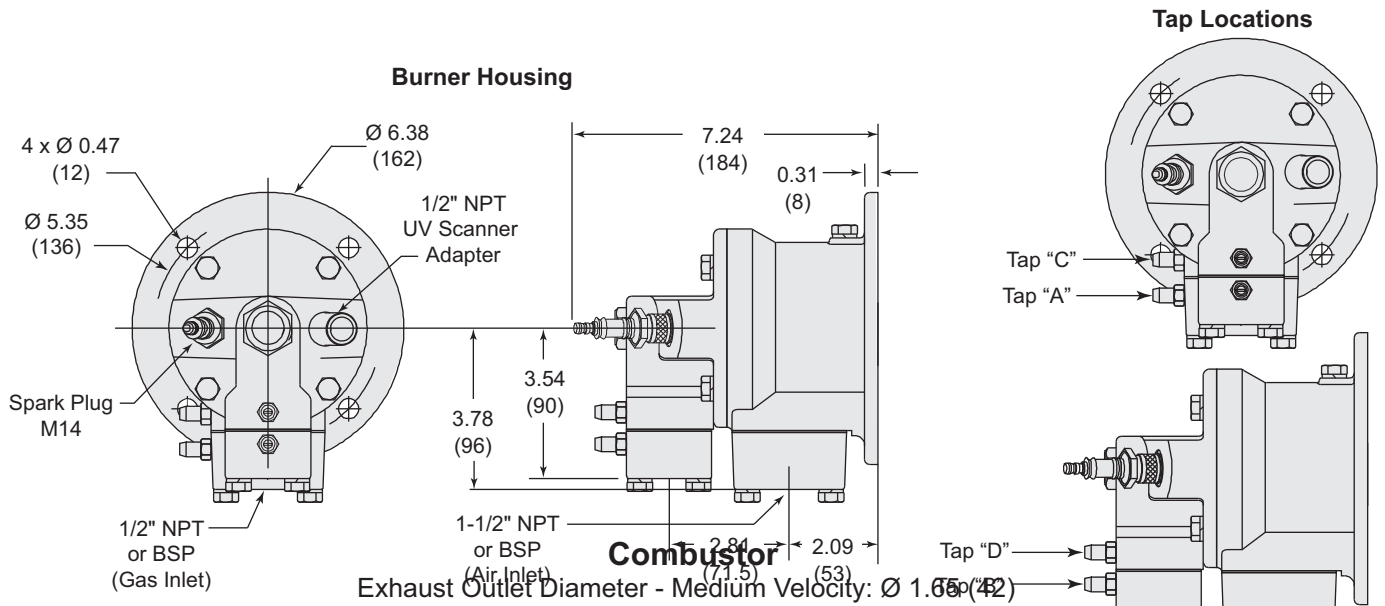

Alloy Tube (AISI 310)

Weight: 2.1 lbs (0.95 kg)

Max. Chamber Temp: 1,750°F (950°C)

(Not suitable for preheated air over 700°F)

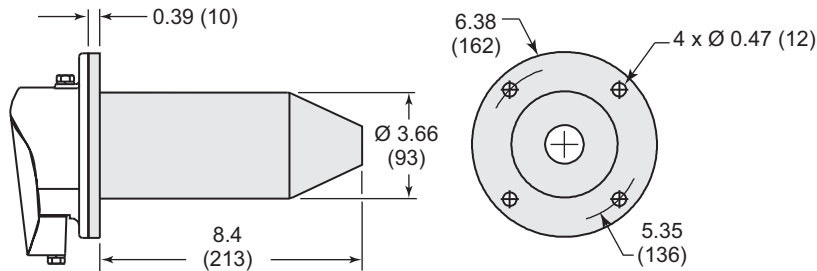

Silicon Carbide Tube

Weight: 3.6 lbs (1.63 kg)

Max. Chamber Temp: 2,200°F (1200°C)

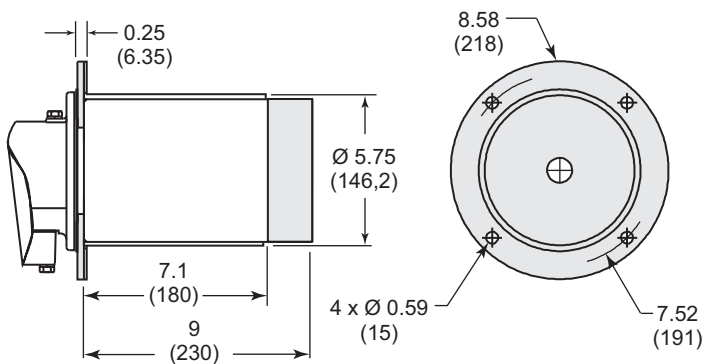

Refractory Block (w/330 SS wrapper)

Weight: 14 lbs (6.35 kg)

Max. Chamber Temp: 2,800°F (1538°C)

