

Eclipse ThermJet Burners

for Preheated Combustion Air

Model TJPCA0100

Version 2

Parameter			Specifications		
			Natural Gas	Propane	Butane
Maximum Input BTU/hr (kW)			1,000,000 (293)	1,000,000 (293)	1,000,000 (293)
Minimum Input, On-Ratio BTU/hr (kW)			100,000 (29)	100,000 (29)	100,000 (29)
Gas Inlet Pressure Required "w.c. (mbar) Fuel Pressure at Gas Inlet (Tap "B" - see page 3)	Combustion Air Temp	Ambient	5.5 (13.7)	8.0 (19.9)	7.5 (18.6)
		300°F (150°C)	6.7 (16.7)	9.2 (22.9)	8.7 (21.7)
		700°F (370°C)	8.9 (22.2)	11.4 (28.4)	10.9 (27.2)
		1000°F (540°C)	10.6 (26.3)	13.1 (32.6)	12.6 (31.3)
Air Inlet Pressure Required "w.c. (mbar) 15% Excess Air at Maximum Input (Tap "A" - see page 3)	Combustion Air Temp	Ambient	3.5 (8.7)	3.5 (8.7)	3.5 (8.7)
		300°F (150°C)	5 (12.5)	5 (12.5)	5 (12.5)
		700°F (370°C)	7.7 (19.2)	7.7 (19.2)	7.7 (19.2)
		1000°F (540°C)	9.6 (23.9)	9.6 (23.9)	9.6 (23.9)
High Fire Flame Length Inches (mm) (Measured from End of Combustor)			<38.0 (965)	<37.0 (940)	<42.0 (1065)
Flame Detection			UV scanner available for all combustors.		
Fuel For any other mixed gas, contact Eclipse for orifice sizing.			Natural gas, propane, or butane		
Approvals			 AI30		

- All information is based on laboratory testing in neutral (0.0" w.c.) pressure chamber. Different chamber size and conditions may affect the data.
- All information is based on standard combustor design. Changes in combustor will alter performance and pressures.
- All inputs based upon gross calorific values.
- Eclipse reserves the right to change the construction and/or configuration of our products at any time without being obliged to adjust earlier supplies accordingly.
- Plumbing of air and gas will affect accuracy of orifice readings. All information is based on generally acceptable air and gas piping practices.

Performance Graphs

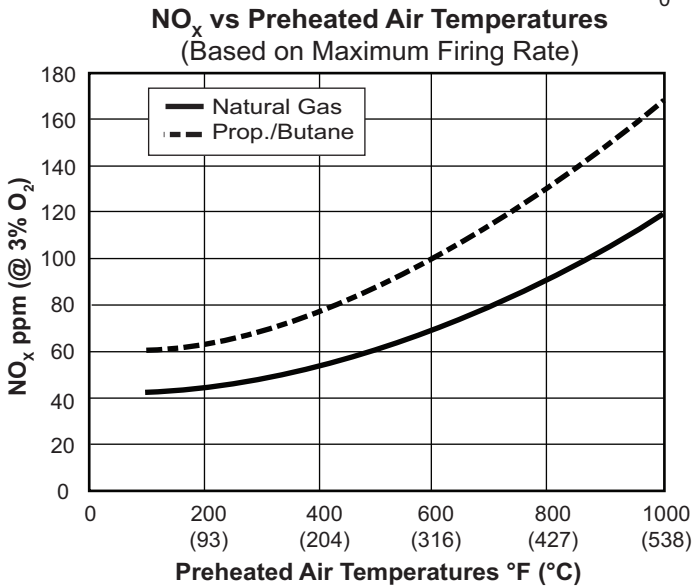
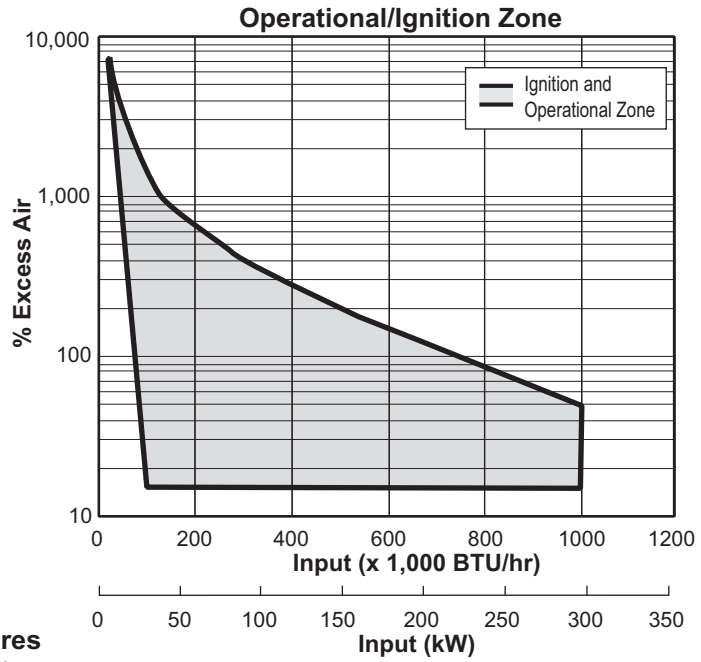

Emissions from the burner are influenced by:

- Fuel type
- Combustion air temperature
- Firing rate
- Chamber conditions
- Percent of excess air

For estimates of other emissions, contact Eclipse.

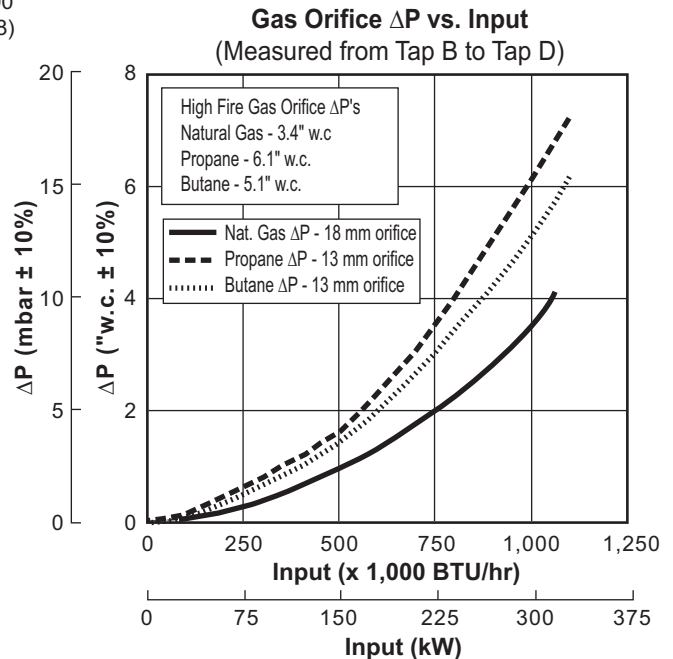

Dimensions in inches (mm)

Burner Housing

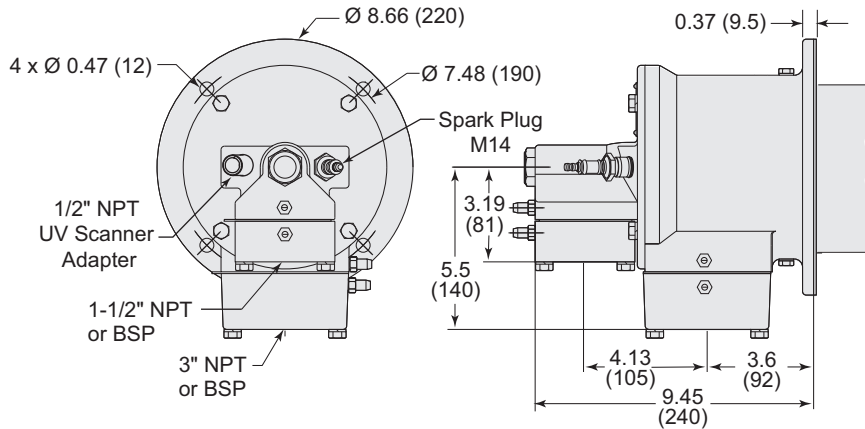

Burner weight less combustor: 42 lbs (19 kg)

Tap Locations

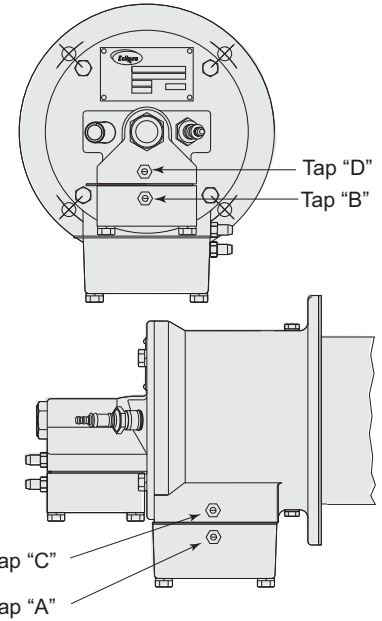

Combustor

Exhaust Outlet Diameter - Medium Velocity: $\text{Ø } 3$ (76.4)

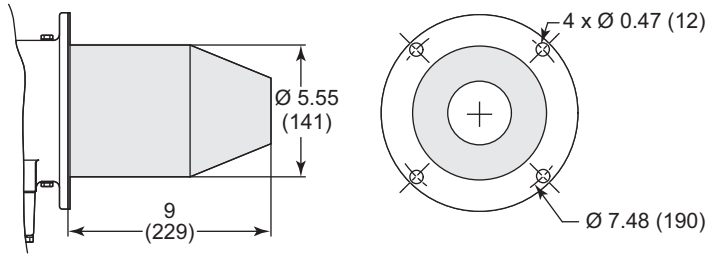

Alloy Tube (AISI 310)

Weight: 3.2 lbs (1.45 kg)
 Max Chamber Temp: 1,750°F (950°C)
 (Not suitable for preheated air over 700°F)

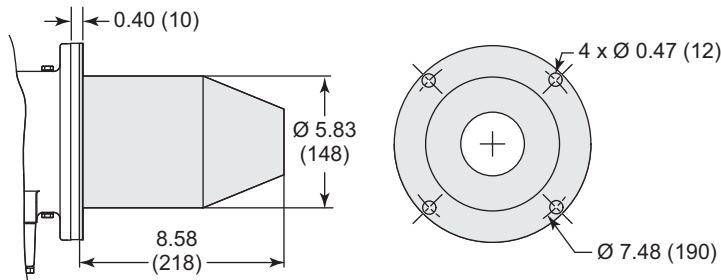

Silicon Carbide Tube

Weight: 3.2 lbs (1.45 kg)
 Max. Chamber Temp: 2,200°F (1200°C)

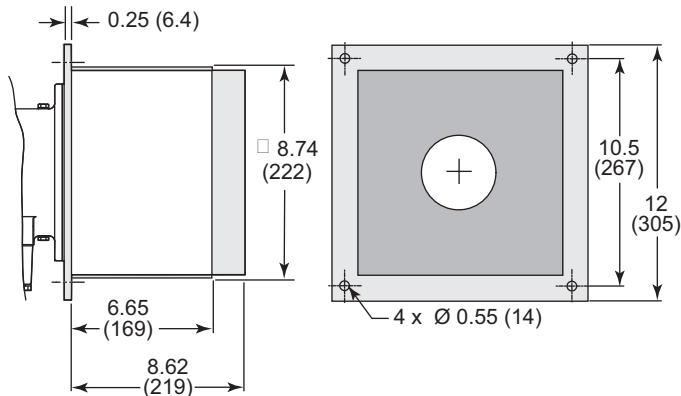

Refractory Block

(w/RA330 wrapper)
 Weight: 61.3 lbs (28 kg)
 Max Chamber Temp: 2,800°F (1538°C)

Down Firing Block

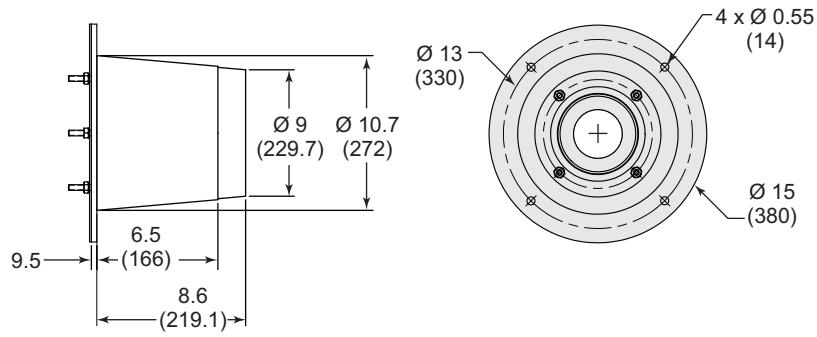

Weight: 75 lbs (34 kg)
Max. Chamber Temp: 2800°F (1535°C)