

Eclipse ThermJet Burners for Preheated Combustion Air

Model TJPCA0500

Version 2

Parameter		Specifications			
		Natural Gas	Propane	Butane	
Maximum Input BTU/hr (kW)		5,000,000 (1465)	5,000,000 (1465)	5,000,000 (1465)	
Minimum Input, On-Ratio BTU/hr (kW)		500,000 (146)	500,000 (146)	500,000 (146)	
Gas Inlet Pressure Required "w.c. (mbar) Fuel Pressure at Gas Inlet <i>(Tap "B" - see page 3)</i>	Combustion Air Temp	Ambient	5.5 (13.7)	6.0 (14.9)	5.5 (13.7)
		300°F (150°C)	7.5 (18.5)	8.0 (19.8)	7.5 (18.5)
		700°F (370°C)	11.0 (27.3)	11.5 (28.6)	11.0 (27.3)
Air Inlet Pressure Required "w.c. (mbar) 15% Excess Air at Maximum Input <i>(Tap "A" - see page 3)</i>	Combustion Air Temp	Ambient	4.8 (12.0)	4.8 (12.0)	4.8 (12.0)
		300°F (150°C)	6.8 (16.9)	6.8 (16.9)	6.8 (16.9)
		700°F (370°C)	10.3 (25.6)	10.3 (25.6)	10.3 (25.6)
Maximum Preheated Air Temperature		700°F (370°C)			
High Fire Flame Length Inches (mm) <i>(Measured from End of Combustor)</i>		<100.0 (2550)	<100.0 (2550)	<105.0 (2670)	
Flame Detection		UV scanner available for all combustors.			
Fuel <i>For any other mixed gas, contact Eclipse for orifice sizing.</i>		Natural gas, propane, or butane.			
Approvals					

- All information is based on laboratory testing in neutral (0.0" w.c.) pressure chamber. Different chamber size and conditions may affect the data.
- All information is based on standard combustor design. Changes in combustor will alter performance and pressures.
- All inputs based upon gross calorific values.
- Eclipse reserves the right to change the construction and/or configuration of our products at any time without being obliged to adjust earlier supplies accordingly.
- Plumbing of air and gas will affect accuracy of orifice readings. All information is based on generally acceptable air and gas piping practices.

Performance Graphs

Ignition & Operational Zones

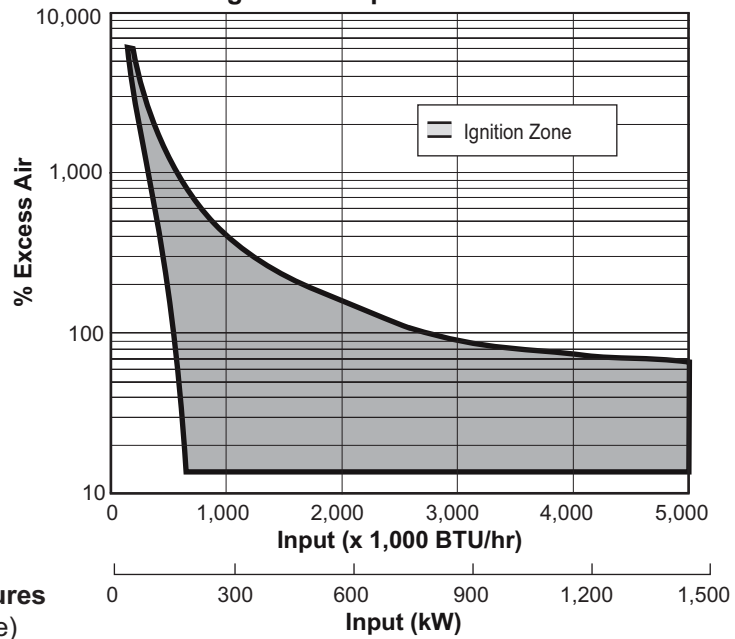

NO_x vs Preheated Air Temperatures (Based on Maximum Firing Rate)

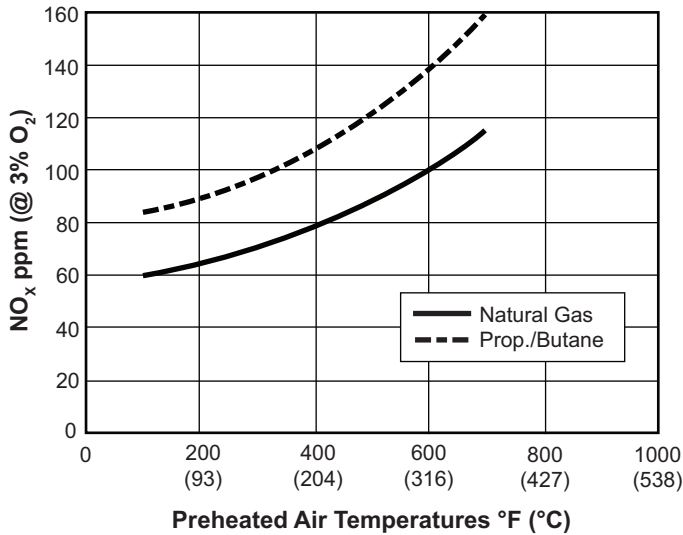

Emissions from the burner are influenced by:

- Fuel type
- Combustion air temperature
- Firing rate
- Chamber conditions
- Percent of excess air

For estimates of other emissions, contact Eclipse.

Gas Orifice ΔP vs. Input (Measured from Tap B to Tap D)

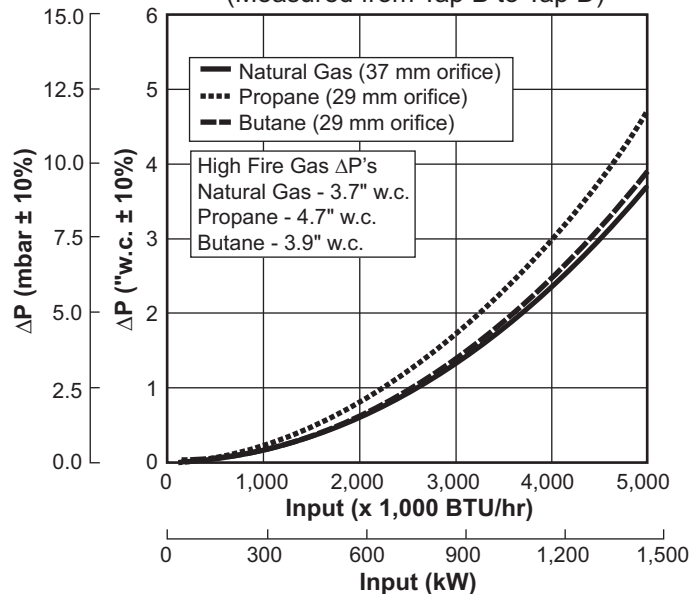

Dimensions in inches (mm)

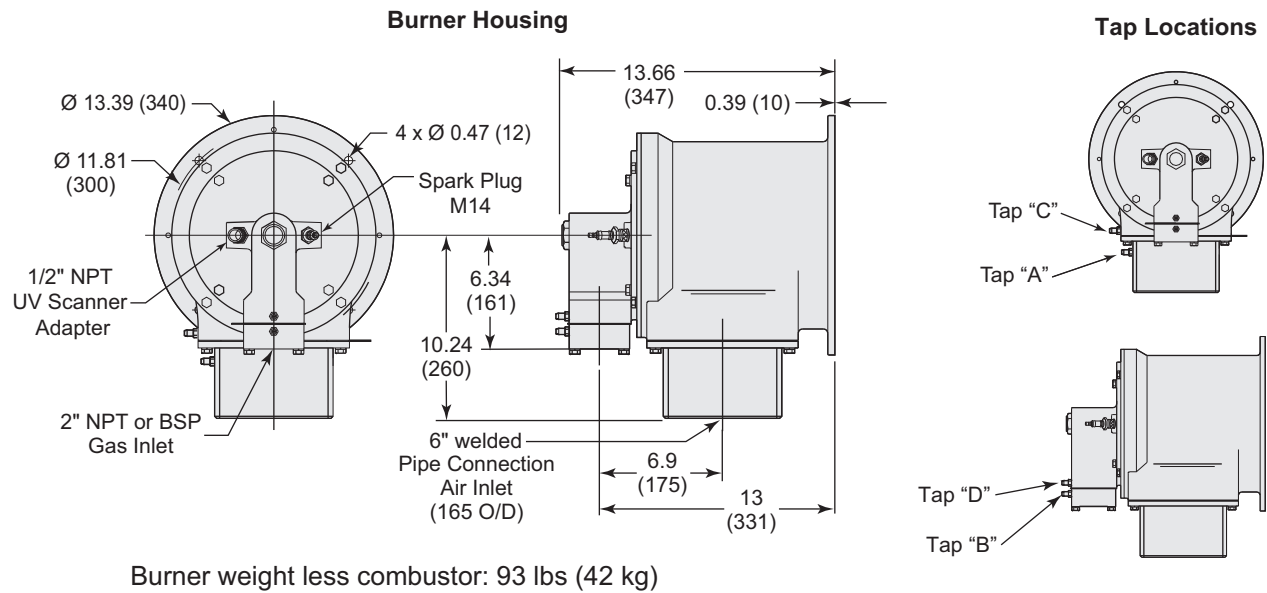

Combustor

Exhaust Outlet Diameter - Medium Velocity: \varnothing 6.97 (177)

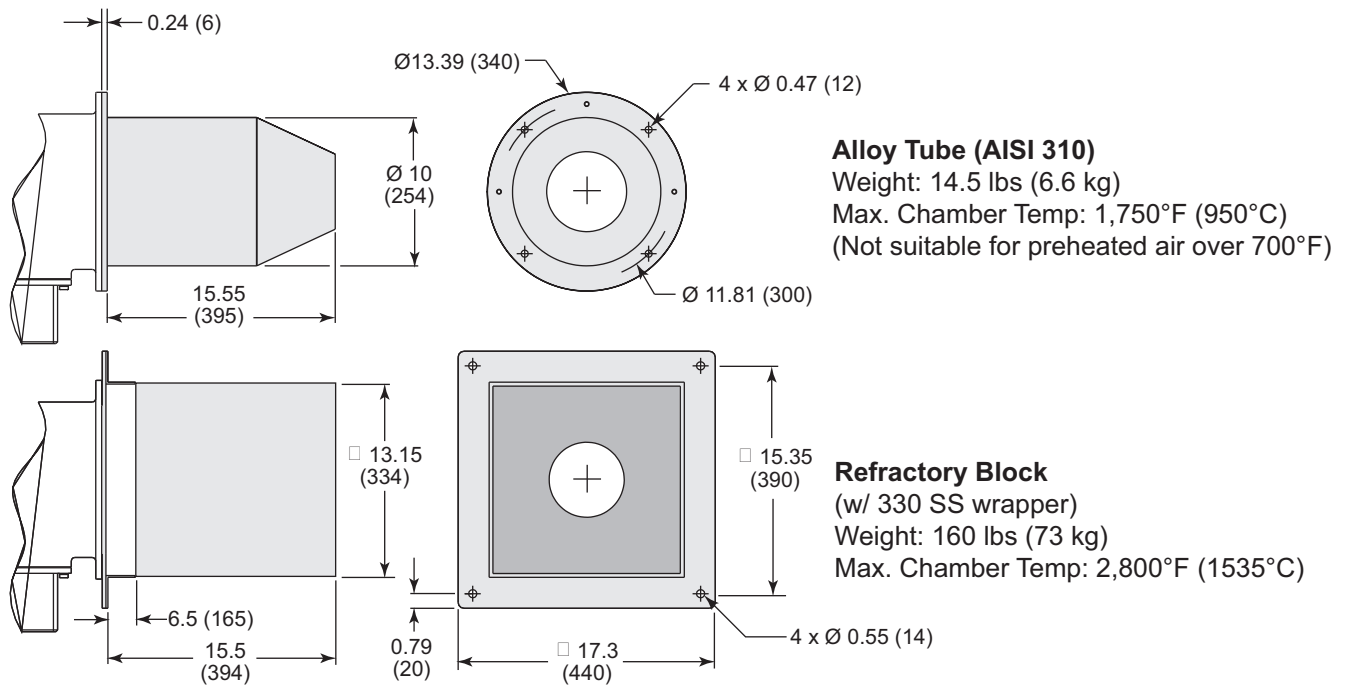

Down Firing Block

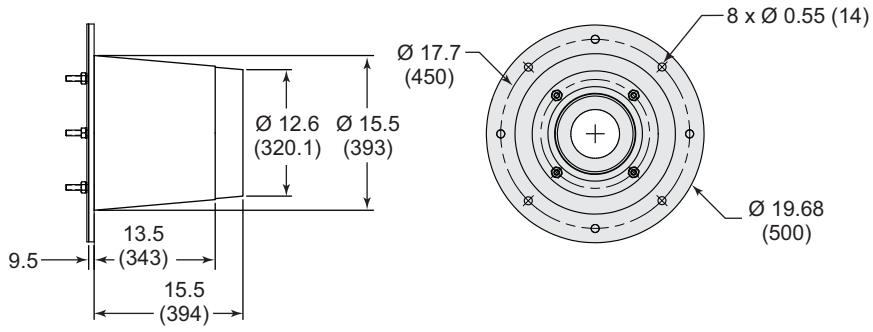

Weight: 185 lbs (83.91 kg)
Max. Chamber Temp: 2800°F (1535°C)