

# Eclipse ThermJet Burners

## for Preheated Combustion Air

Model TJPCA1500

Version 2

Parameter		Specifications			
		Natural Gas	Propane	Butane	
Maximum Input BTU/hr (kW)		15,000,000 (4395)	15,000,000 (4395)	15,000,000 (4395)	
Minimum Input, On-Ratio BTU/hr (kW)		1,500,000 (440)	1,500,000 (440)	1,500,000 (440)	
Gas Inlet Pressure Required "w.c. (mbar) Fuel Pressure at Gas Inlet (Tap "B" - see page 3)	Combustion Air Temp	Ambient	3.7 (9.2)	3.7 (9.2)	3.7 (9.2)
		300°F (150°C)	5.5 (13.6)	5.5 (13.6)	5.5 (13.6)
		700°F (370°C)	8.8 (21.7)	8.8 (21.7)	8.8 (21.7)
		1000°F (540°C)	11.2 (27.8)	11.2 (27.8)	11.2 (27.8)
Air Inlet Pressure Required "w.c. (mbar) 15% Excess Air at Maximum Input (Tap "A" - see page 3)	Combustion Air Temp	Ambient	4.4 (10.9)	4.4 (10.9)	4.4 (10.9)
		300°F (150°C)	6.2 (15.4)	6.2 (15.4)	6.2 (15.4)
		700°F (370°C)	9.5 (23.5)	9.5 (23.5)	9.5 (23.5)
		1000°F (540°C)	11.9 (29.5)	11.9 (29.5)	11.9 (29.5)
High Fire Flame Length Inches (mm) (Measured from End of Combustor)		<144.0 (3660)	<185.0 (4700)	<185.0 (4700)	
Flame Detection		UV scanner available for all combustors.			
Fuel For any other mixed gas, contact Eclipse for orifice sizing.		Natural gas, propane, or butane.			
Approvals					

- All information is based on laboratory testing in neutral (0.0" w.c.) pressure chamber. Different chamber size and conditions may affect the data.
- All information is based on standard combustor design. Changes in combustor will alter performance and pressures.
- All inputs based upon gross calorific values.
- Eclipse reserves the right to change the construction and/or configuration of our products at any time without being obliged to adjust earlier supplies accordingly.
- Plumbing of air and gas will affect accuracy of orifice readings. All information is based on generally acceptable air and gas piping practices.

# Performance Graphs

## Ignition & Operational Zones

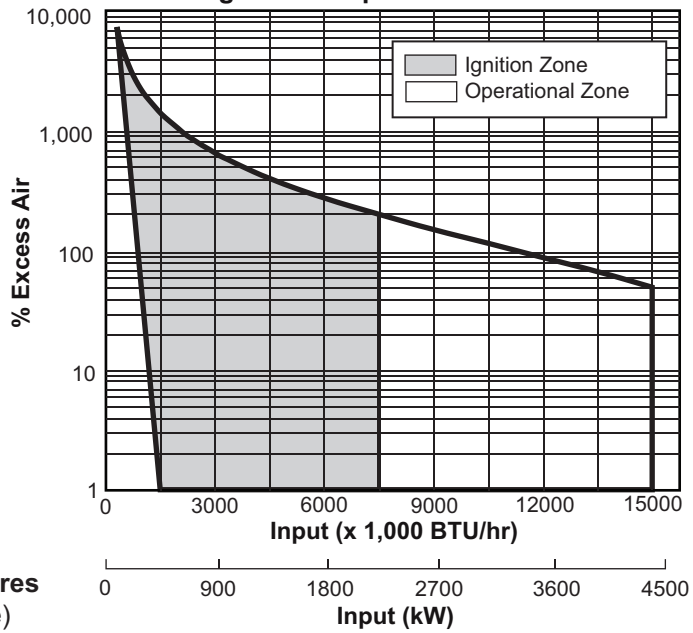

## NO<sub>x</sub> vs Preheated Air Temperatures (Based on Maximum Firing Rate)

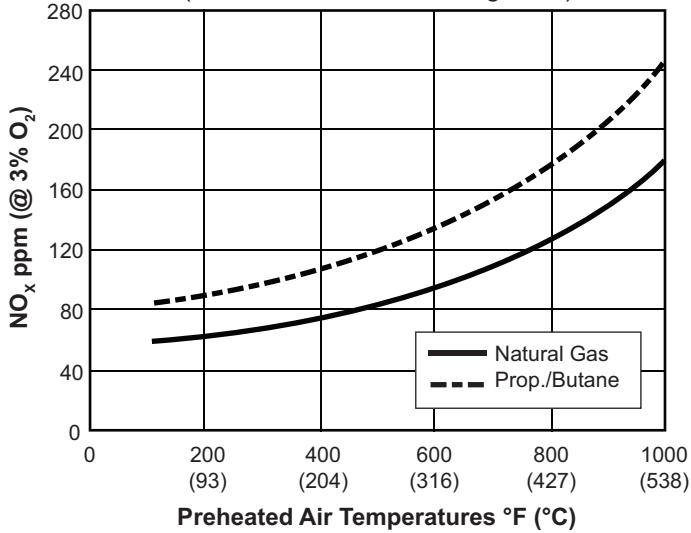

Emissions from the burner are influenced by:

- Fuel type
- Combustion air temperature
- Firing rate
- Chamber conditions
- Percent of excess air

For estimates of other emissions, contact Eclipse.

## Gas Orifice ΔP vs. Input (Measured from Tap B to Tap D)

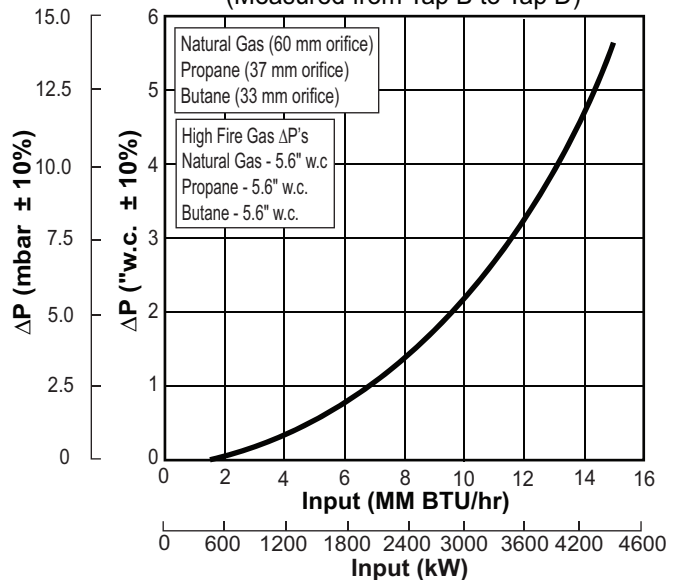

## Dimensions in inches (mm)

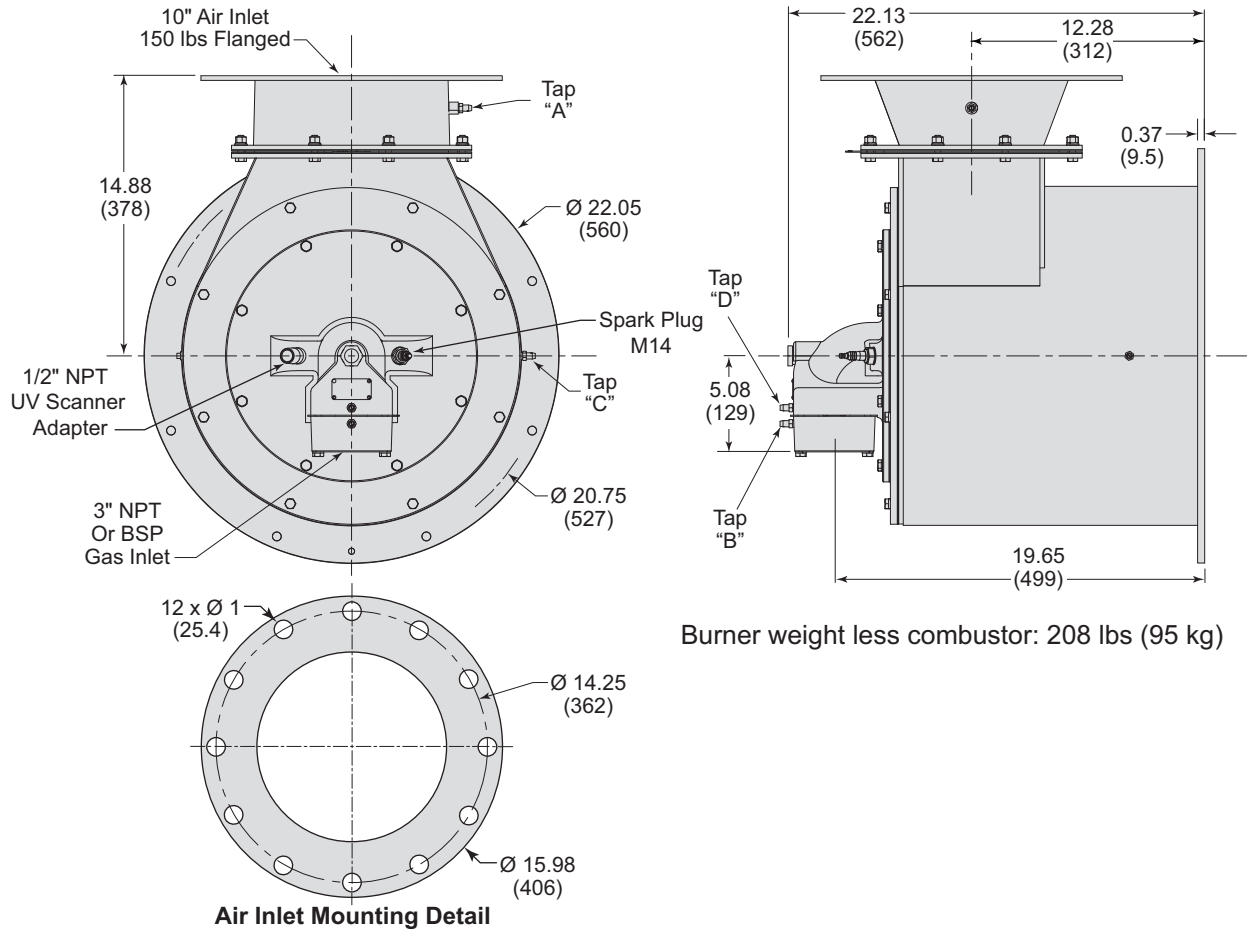

### Combustor

Exhaust Outlet Diameter - Medium Velocity (Straight): Ø 15.16 (385)

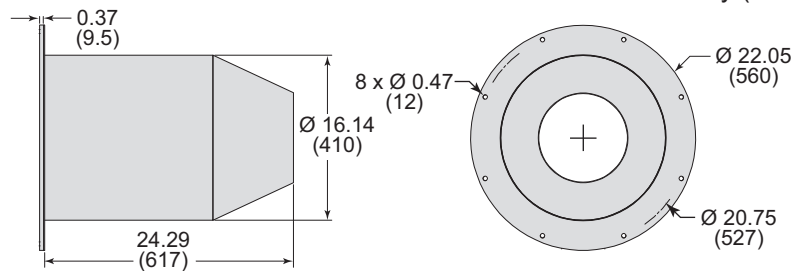

#### **Alloy Tube (AISI 310)**

Weight: 44 lbs (20 kg)

Max. Chamber Temp: 1,750°F (950°C)

(Not suitable for preheated air over 700°F)

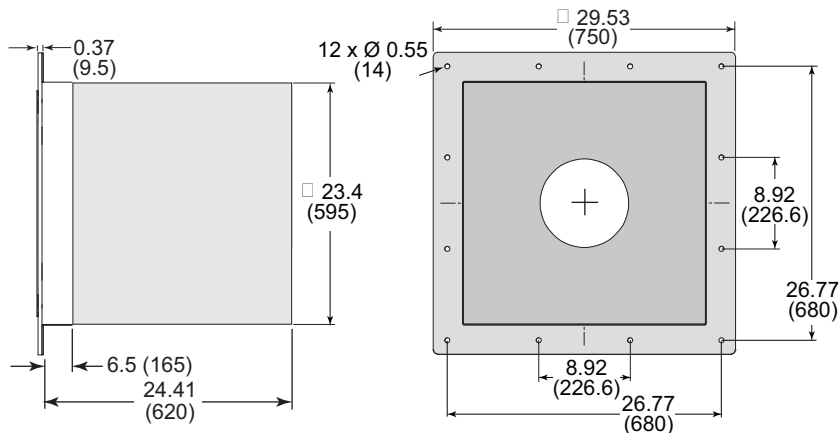

#### **Refractory Block**

(w/330 SS wrapper)

Weight: 1000 lbs (454 kg)

Max. Chamber Temp: 2,800°F (1535°C)

# Down Firing Block

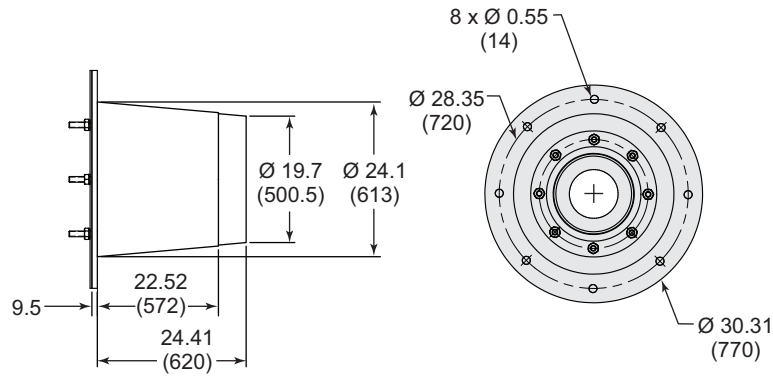

Weight: 610 lbs (276.69 kg)  
Max. Chamber Temp: 2800°F (1535°C)