

# MRO

## Oil-Air Ratio Regulator



### *Features*

- Efficiently handles No. 1 through No. 6 fuel oil
- Wide capacity range
- Provides automatic and simple method of maintaining air/oil ratio - even at extremely low flow rates

### *Benefits*

- Easy to maintain
- Accurate and repeatable
- Wide turndown



MRO regulators serve as the control device in a cross-connected oil-air delivery system requiring wide turndown and/or low flow rates. They function properly over a wide range of air pressures. MRO regulators are for use in single or multiple burner applications.

## HAUCK MANUFACTURING COMPANY

P.O. Box 90  
Lebanon, PA 17042  
Phone: 717-272-3051  
Fax: 717-273-9882  
[www.hauckburner.com](http://www.hauckburner.com)

**Combustion Excellence Since 1888**

# MRO

## OIL-AIR RATIO REGULATOR



### ADVANTAGES OF THE MRO

- Wide Turndown
- Easy to Maintain
- Accurate and Repeatable
- Wide Capacity Range

The Hauck MRO oil-air ratio regulators are designed to serve as the essential control device in a cross connected oil-air delivery system on applications requiring wide turndown and/or low flow rates and repeatability. The MRO is engineered to function properly over a wide range of air pressures and may be used on either single or multiple burner applications. A constant oil pressure is required at the inlet of the regulator.

**Application.** In burners where air discharge openings are fixed and the firing rate is changed by varying the air pressure, the desired ratio of oil flow to air flow can be secured by regulating the oil pressure in direct proportion to the air pressure. The MRO provides an automatic and simple means of maintaining this ratio even at extremely low flow rates.

A connection is provided on the regulator for an air pressure sensing line. This line extends from the MRO to a connection on the downstream side of the air control valve in the secondary combustion air supply line and the sensing line to the MRO. The MRO translates these variations into proportional changes in the oil pressure. The MRO automatically varies the oil pressure in exact proportion to the air delivered to the burners. Thus, the desired ratio of oil to air is constantly maintained. If the secondary air pressure is greater than 16 psi (6.9 kPa), an air impulse filtered bleed assembly must be installed into the air pressure sensing line to the MRO for precise control of air and fuel oil to the burners.

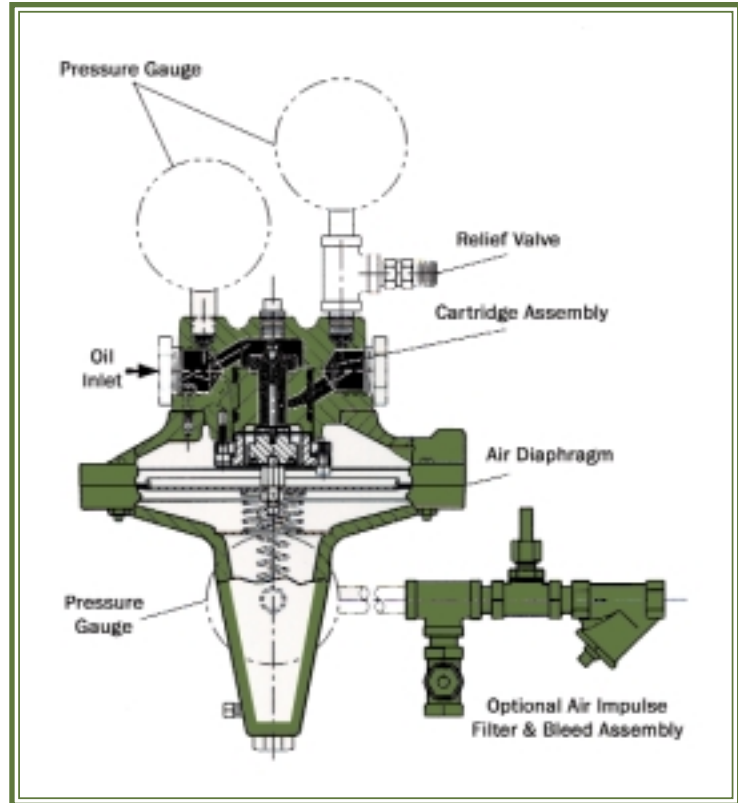

**View of the MRO ratio regulator showing its internal components and the oil flow path.**

The Hauck MRO ratio regulator is engineered to function accurately over a wide range of air pressures using No. 1 through No. 6 fuel oil. The MRO will operate at oil temperatures from 0 to 270°F (-18 to 132°C).

The MRO must be preceded in the oil line by a suitable filter. Use of clean air and oil greatly enhance the operational life of the MRO.

**Easy to Maintain.** Each MRO regulator is designed to allow it to be dismantled without removing it from the oil line. Critical elements, such as the air diaphragm and the valve cartridge, are engineered to allow them to be removed and replaced as a packaged unit. This allows trouble-free replacement which greatly reduces maintenance downtime.



**MRO OIL-AIR RATIO REGULATOR**

Ratio Regulator Model No.	Oil Connection		Oil Capacity			
			(gph)		(lph)	
	NPT	DN	Min.	Max.	Min.	Max.
MRO 105	1/2	15	0.75	50	2.8	189
MRO 107	3/4	20	2.0	100	7.6	379
MRO 207	3/4	20	6.0	465	23	1760

Notes:

1. Oil Capacities based on No. 2 fuel oil at 0.87 S.G. and 60°F (15.6°C).
2. Recommended inlet oil pressure for 16 osig (6.9 kPa) air impulse pressure is 45-65 psig (310-448 kPa).
3. If air impulse pressure is greater than 16 osig (6.9 kPa), an air impulse filter and bleed assembly must be installed in the air impulse line to the MRO for precise control of the air/fuel ratio to the burner. For example, if the burner secondary air impulse pressure is 32 osig (13.8 kPa), the air impulse filter and bleed assembly is used to reduce the air impulse signal to 16 osig (6.9 kPa) at the MRO for high fire at the burner. The air/fuel ratio is maintained by adjusting high fire oil flow with the micro oil valve located at the burner, and adjusting low fire oil flow with the adjusting screw located on the bottom of the MRO.

In accordance with Hauck's commitment to Total Quality Improvement, Hauck reserves the right to change the specifications of products without prior notice.

**MRO OIL-AIR RATIO REGULATOR**

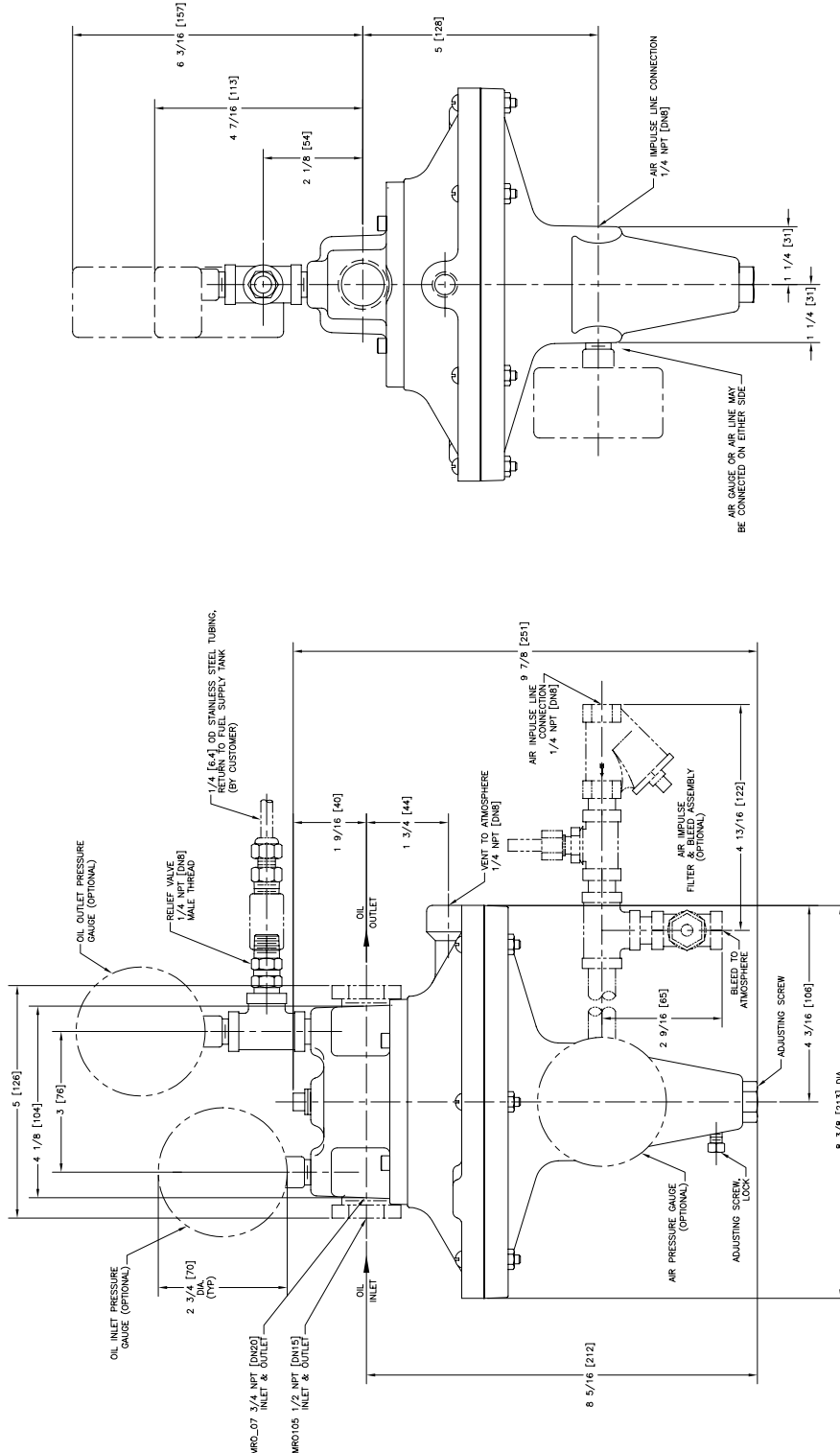

CY2182

- NOTES:
1. ALL DIMENSIONS ARE IN INCHES [MM]; PIPE CONNECTIONS ARE IN NPT [DN].
  2. ALL PRESSURE GAUGE CONNECTIONS ARE 1/4 NPT [DN8].
  3. AIR IMPULSE FILTER & BLEED ASSEMBLY REQUIRED IF IMPULSE AIR PRESSURE IS GREATER THAN 16 OSIG [6.9 KPA].

In accordance with Hauck's commitment to Total Quality Improvement, Hauck reserves the right to change the specifications of products without prior notice.

## MRO OIL-AIR RATIO REGULATOR

### OPERATION

The oil enters the regulator as shown in Figure 1 and passes through the single-seat valve assembly on its way to the outlet. A single-seat design is used to allow the accurate control of extremely low flow rates – as low as 0.75 gph (2.8 lph) for the MRO 105, 2 gph (7.6 lph) for the MRO 107 and 6 gph (23 lph) for the MRO 207.

The air pressure at the burner(s) is supplied to the MRO by a cross-connected air impulse line. The air pressure causes an upward force on the air diaphragm. It is this upward force which must be balanced by the downward pressure of the oil on the oil diaphragm. The air to oil diaphragm area ratio is 30:1 which theoretically correlates to a 30:1 outlet pressure turndown. However, the outlet pressure turndown in any system may vary from 20:1 to 40:1 as a result of different oil inlet pressure, downstream oil piping, and burner oil flow requirements. Once an MRO is adjusted for a given system, the outlet pressure turndown will remain constant. If the secondary air pressure is greater than 16 osig (6.9 kPa), an air impulse filter and bleed assembly must be installed in the air impulse line to the MRO to ensure precise control of air/fuel oil to the burners.

In addition, the high air to oil diaphragm area ratio, coupled with the high input pressures of 45 - 65 psig (310 - 448 kPa) allows high output pressures. The wide range of output capacity, from 0.75 - 465 gph (2.8 - 1760 lph) depending on the model, results in a wide turndown range.

The MRO is installed in the oil supply line as close to the burner(s) as possible without exposing the regulator to direct heat. The outlet of the MRO can not be located more than 6" lower than the horizontal centerline of the burner oil valve for horizontally mounted burners, or the burner nozzle discharge for vertically mounted down-fired burners.

Each MRO regulator is equipped with a pressure relief valve to protect the regulator internals from damage caused by excessive oil pressures. The relief valve is shipped set at 75 psig (517 kPa) but can easily be reset within its 50 - 150 psig (345 - 1034 kPa) operating range.

A separate oil pressure regulator located upstream of the MRO is recommended to maintain precise control of the furnace atmosphere. In addition, a suitable oil filter must be located upstream of the MRO. The filter can be supplied separately or as part of an MRO regulator-filter assembly, contact Hauck.

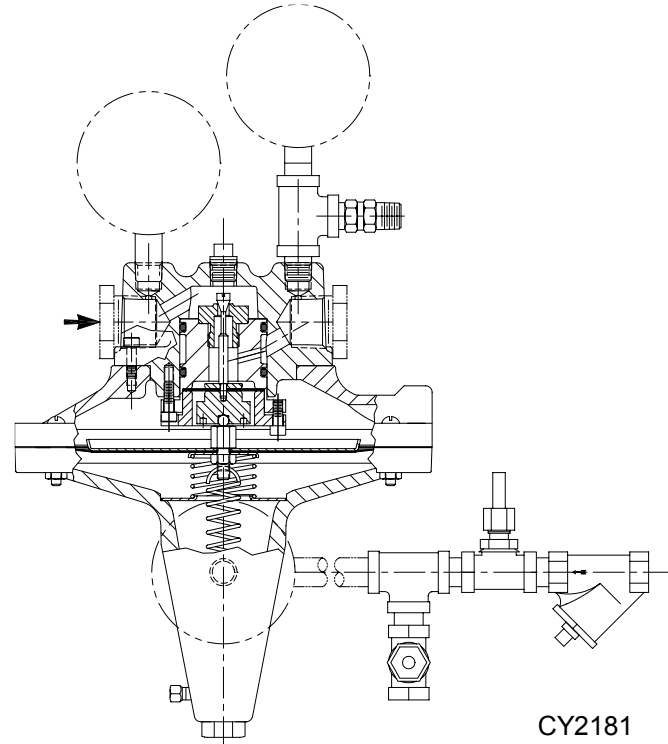

**Figure 1. MRO Regulator With Optional Air Impulse Filter and Bleed Assembly**

In accordance with Hauck's commitment to Total Quality Improvement, Hauck reserves the right to change the specifications of products without prior notice.

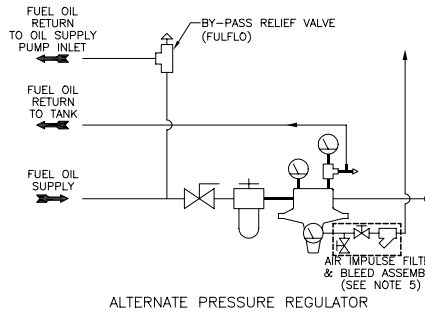
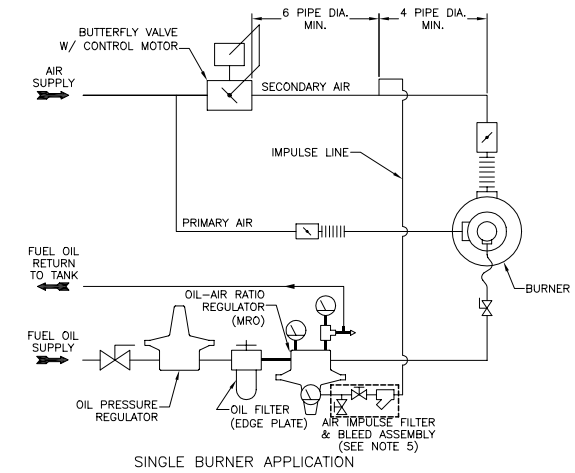
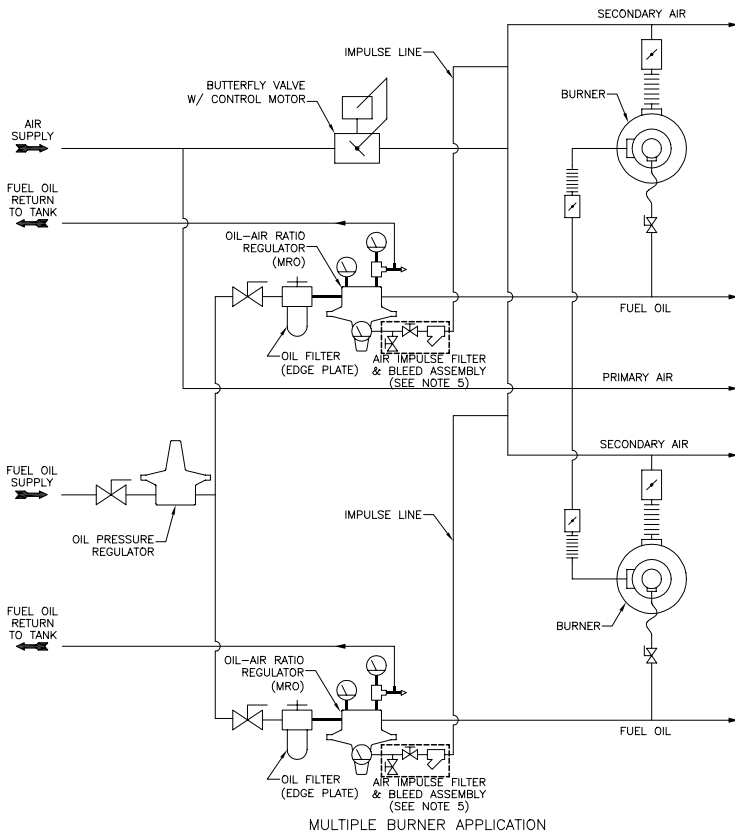

CY2179

- NOTE: 1. RELIEF VALVE ON OIL-AIR RATIO REGULATOR SET AT THE GREATER OF 75 PSIG (517 KPA) MINIMUM OR 5 PSIG (34.5 KPA) ABOVE OIL SUPPLY PRESSURE.  
 2. OIL-AIR RATIO REGULATOR OUTLET CAN NOT BE LOCATED MORE THAN 6" (152MM) LOWER AND NEVER HIGHER THAN THE CENTER LINE OF THE BURNER OIL VALVE FOR HORIZONTALLY MOUNTED BURNERS, OR THE BURNER NOZZLE DISCHARGE FOR VERTICALLY MOUNTED DOWN-FIRED BURNERS. OIL-AIR RATIO REGULATOR MUST BE MOUNTED WITHIN 20' (6M) OR LESS OF THE OIL VALVE AT THE BURNER.  
 3. HEAVY OIL SUPPLY SYSTEM (NOT SHOWN) IS AN INTEGRAL PART OF ANY HEAVY OIL BURNER SYSTEM. TYPICAL COMPONENTS INCLUDE SUCTION HEATER, SUPPLY PUMPING UNIT, AND LINE HEATER. HOWEVER, REQUIREMENTS ARE DEPENDENT UPON THE SPECIFIC BURNER SYSTEM (CONSULT HAUCK).

4. ALL HEAVY FUEL OIL PIPING MUST BE TRACED (ELECTRIC OR STEAM) AND INSULATED. SELF-REGULATING HEAT TRACING IS RECOMMENDED TO MAINTAIN THE DESIRED TEMPERATURE OF A GIVEN FUEL OIL; NO. 4 FUEL OIL @ 160°F (71°C), NO. 6 OIL @ 250°F (121°C). ELECTRICAL HEAT TRACING WITH A NOMINAL RATING OF 12 W/FT (34W/M) COVERED WITH A NOMINAL 2" (51MM) FIBERGLASS TYPE INSULATION IS SUFFICIENT FOR MOST APPLICATIONS.  
 5. AIR IMPULSE FILTER & BLEED ASSEMBLY MUST BE INSTALLED IN THE AIR IMPULSE LINE TO THE MRO IF THE SECONDARY AIR PRESSURE IS GREATER THAN 16 OSIG (6.9 KPA).

Figure 2. Typical MRO Piping Schematics

### SINGLE VALVE CONTROL

The MRO allows the furnace atmosphere to be closely controlled since it serves as a centralized, single valve operational control for either single or multiple burner applications. One ratio regulator should be used for each control zone. A control zone may contain one or more burners (and one or more ratio regulators), but the capacity of each regulator must be equal to or greater than the sum of the capacities of all the burners which it supplies.

### ELEVATION

Elevation is a critical factor in the installation of any ratio regulator for oil use. For this reason the outlet of the MRO must not be more than 6" lower, and never higher than the center-line of the burner oil valve for horizontally mounted burners, or the burner nozzle discharge for vertically mounted down-fired burners. If the burners in a zone are located with variations in elevation which make it impossible to meet this requirement with one regulator, additional regulators are required. For recommendations on MRO placement in complex applications, consult Hauck.