

# Variable air/gas ratio controls GIKH

Technical Information · GB

2 Edition 08.12



- For maintaining a constant mixture of gas and air on systems using preheated air
- Design with inlet pressure compensation diaphragm ensures high control accuracy
- Adjustment of the gas flow to the air flow that varies due to the heating of the combustion air
- Variable air/gas ratio controls with differential pressure measuring unit for the control pressure
- Wide control range
- EC type-tested and certified
- Certified by Gosstandart pursuant to GOST-TR



# Contents

- Variable air/gas ratio controls GIKH . . . . . 1
- Contents . . . . . 2
- 1 Application . . . . . 3
  - 1.1 Examples of application . . . . . 4
    - 1.1.1 Continuous control . . . . . 5
    - 1.1.2 Continuous control for nominal sizes > DN 25 . . . . . 5
- 2 Certification . . . . . 6
- 3 Function . . . . . 7
- 4 Flow rate . . . . . 8
  - 4.1 Bypass screw flow rate . . . . . 9
- 5 Selection . . . . . 10
  - 5.1 Type code . . . . . 10
- 6 Project planning information . . . . . 11
  - 6.1 Installation . . . . . 11
- 7 Technical data . . . . . 12
  - 7.1 Dimensions . . . . . 12
- 8 Maintenance cycles . . . . . 13
- Feedback . . . . . 14
- Contact . . . . . 14

## 1 Application



*GIKH*

The variable air/gas ratio control GIKH serves to maintain a constant gas/air pressure ratio and to control the gas pressure in systems using a recuperative air preheating system. When the burner capacity is changed and with varying combustion air temperature, the gas pressure is controlled such that the ratio (gas to cold air) remains constant.

For use in systems using preheated air in the iron, steel, glass and ceramics industries, as well as in commercial heat generation, such as the packaging, paper and foodstuffs industries.

## 1.1 Examples of application



*Bogie hearth furnace*



*Bogie hearth furnace*

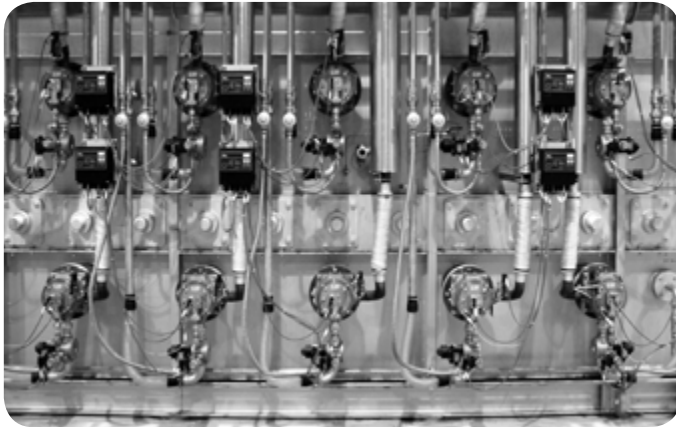

*Roller hearth furnace*

### 1.1.1 Continuous control

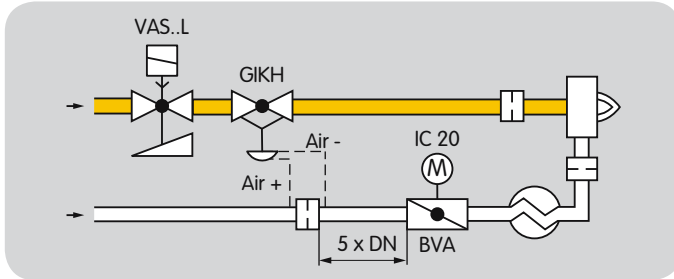

Continuous variable air/gas ratio control on one or multiple burners in hot-air operating mode. In multiple burner systems, the burners downstream of the measuring orifice may not be switched off individually. Safety valves which open slowly in the case of continuous control must always be installed upstream of the air/gas ratio control GIKH.

### 1.1.2 Continuous control for nominal sizes > DN 25

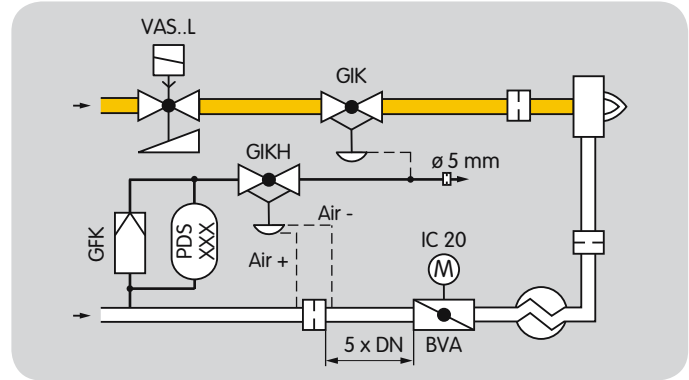

Continuous variable air/gas ratio control on one or multiple burners in hot-air operating mode for gas pipes larger than DN 25. In multiple burner systems, the burners downstream of the measuring orifice may not be switched off individually. Safety valves must always be installed upstream of the air/gas ratio control GIK. These safety valves must open slowly in the case of continuous control.

## 2 Certification

### EC type-tested and certified



pursuant to

- Gas Appliances Directive (2009/142/EC) in conjunction with DIN EN 12067-1.

### Approval for Russia



Certified by Gosstandart pursuant to GOST-TR.

Approved by Rostekhnadzor (RTN).

Scan of the approval for Russia (RUS) – see [www.docuthek.com](http://www.docuthek.com)

→ Elster Kromschöder → Products → 02 Pressure regulators

→ Variable air/gas ratio controls GIKH → Kind of document:

Certificate → GIKH B00093 (nationales Zertifikat Russland) (RUS).

### 3 Function

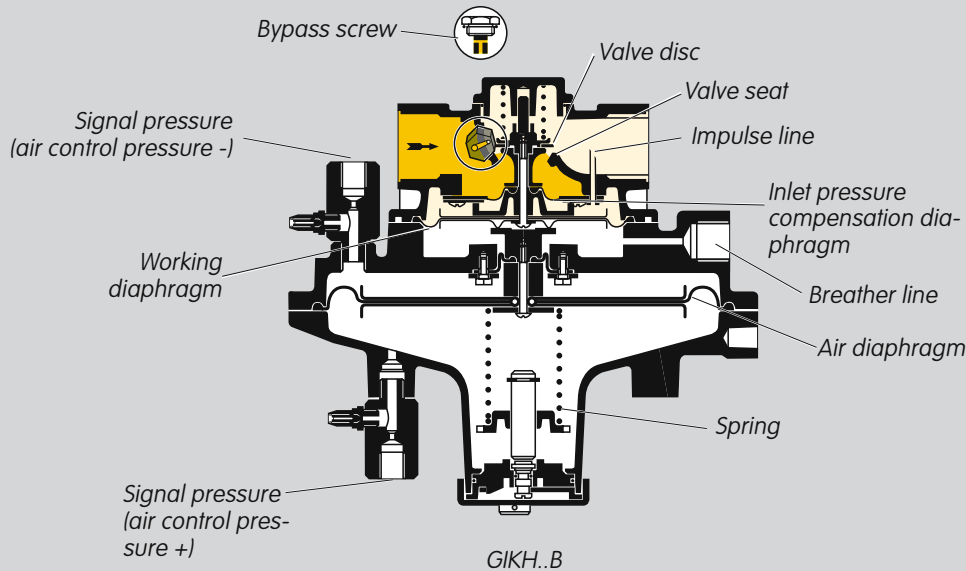

Variable air/gas ratio control GIKH is actuated by the differential pressure on the orifice in the air line. This pressure acts on the large air diaphragm. The valve disc is lifted from the valve seat and the gas flows into the regulator outlet area via the open valve seat. The outlet pressure is fed from the gas side to the space above the working diaphragm via the impulse line. The two pressure forces are compared and compensated. Thanks to the differing diaphragm diameters, the forces are balanced at a pressure ratio of 4:1. The inlet pressure compensation diaphragm ensures high control accuracy.

The spring can be used for compensating the weight of the measuring unit. In the low-fire range, the gas/air mixture can be set by adjusting the spring.

Adjustment at high-fire rate is carried out using orifices or valves on the burner.

The zero shut-off prevents an increase in the outlet pressure when the consumer is switched off.

A test nipple has been installed to measure the outlet pressure.

## 4 Flow rate

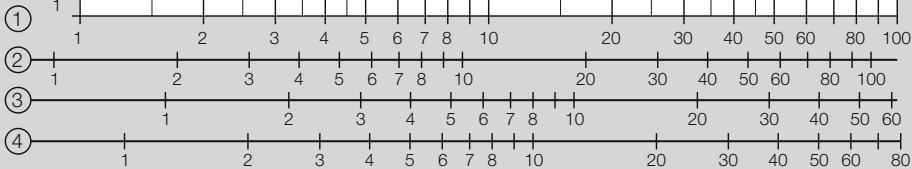
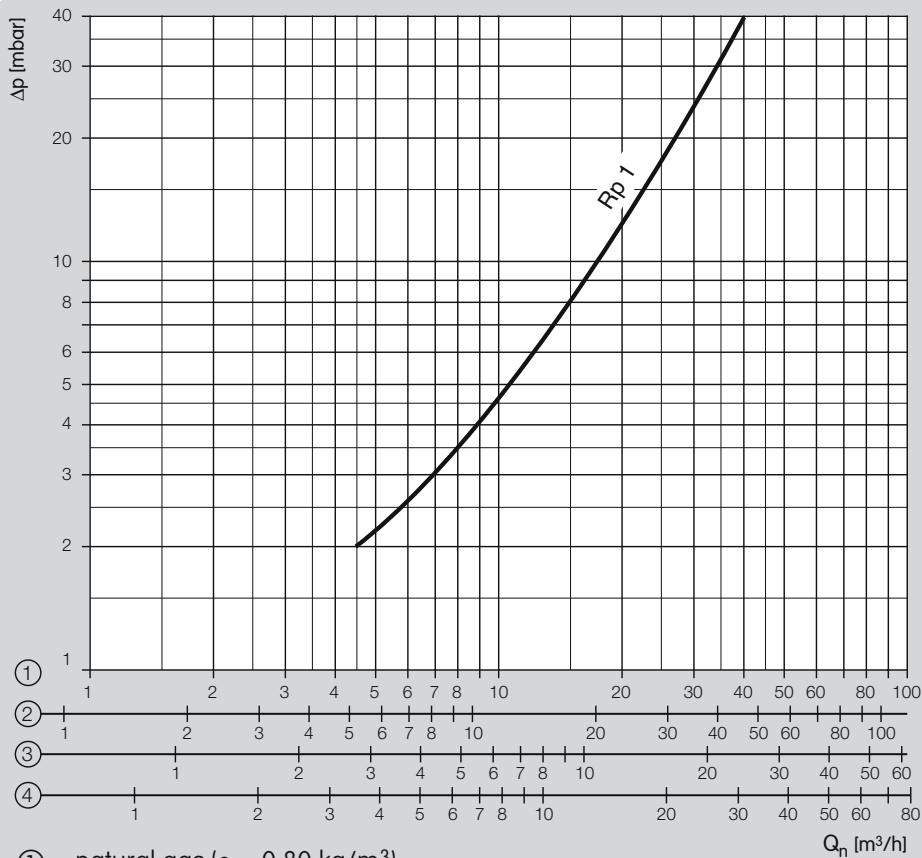

① = natural gas ( $\rho = 0.80 \text{ kg/m}^3$ )

② = town gas ( $\rho = 0.64 \text{ kg/m}^3$ )

③ = LPG ( $\rho = 2.01 \text{ kg/m}^3$ )

④ = air ( $\rho = 1.29 \text{ kg/m}^3$ )



### 4.1 Bypass screw flow rate

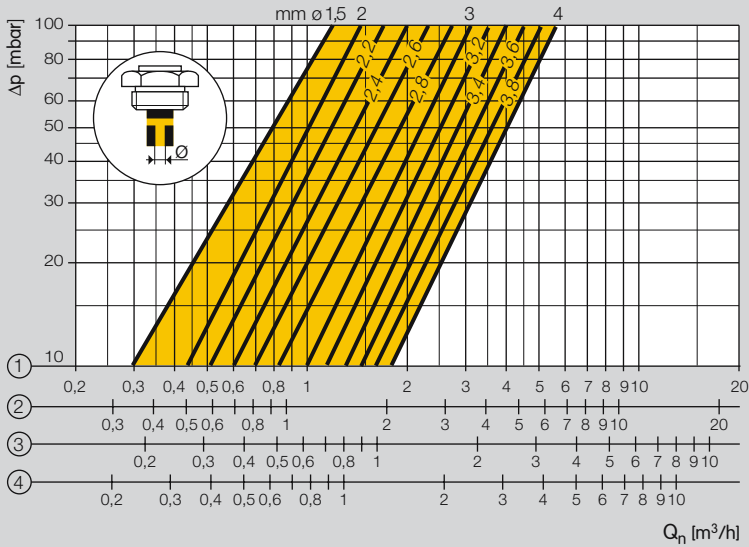

- ① = natural gas ( $\rho = 0.80 \text{ kg/m}^3$ )
- ② = town gas ( $\rho = 0.64 \text{ kg/m}^3$ )
- ③ = LPG ( $\rho = 2.01 \text{ kg/m}^3$ )
- ④ = air ( $\rho = 1.29 \text{ kg/m}^3$ )

## 5 Selection

Variable air/gas ratio control GIKH is available in a single nominal size.

### 5.1 Type code

Code	Description
GIKH	Variable air/gas ratio control
25	Nominal size
R	Rp internal thread
02	$p_U$ max. 200 mbar
-5	Pressure test point at the outlet
L*	For air only (without approval)
B	With bypass screw

\* If "none", this letter is omitted.

## 6 Project planning information

An Rp ½ breather line must be connected when fitting into the gas line.

### 6.1 Installation

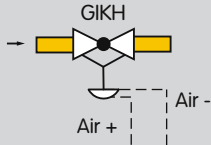

Installation position: spring dome pointing downwards.

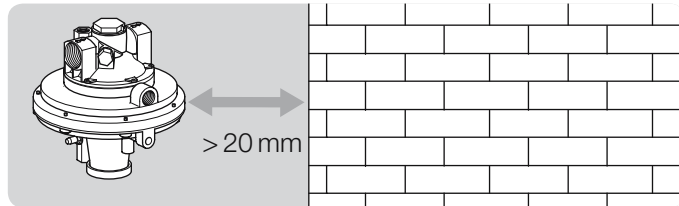

The variable air/gas ratio control GIKH must not be in contact with masonry. Minimum clearance 20 mm.

Do not store or install the unit in the open air.

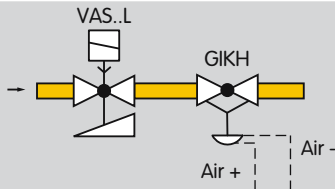

Safety valves VAS..L must always be installed upstream of the variable air/gas ratio control GIKH. These must be slow opening valves.

## 7 Technical data

Gas types: natural gas, town gas, LPG (gaseous) and biologically produced methane (max. 0.02 %-by-vol. H<sub>2</sub>S), GIKH..L also for air. The medium must be dry in all temperature conditions and must not contain condensate.

Inlet pressure  $p_U$ : max. 200 mbar.

Differential between inlet and outlet pressures: max. 100 mbar.

Ambient temperature: -20 to +60°C.

Storage temperature: -20 to +40°C.

Housing: aluminium.

Valve seat and stem: aluminium.

Valve disc: plastic.

Valve disc seal: NBR.

Diaphragms: NBR.

Bypass screw: brass.

When used for air: special version.

Internal thread: Rp to ISO 7-1.

Weight: 3.4 kg.

## 7.1 Dimensions

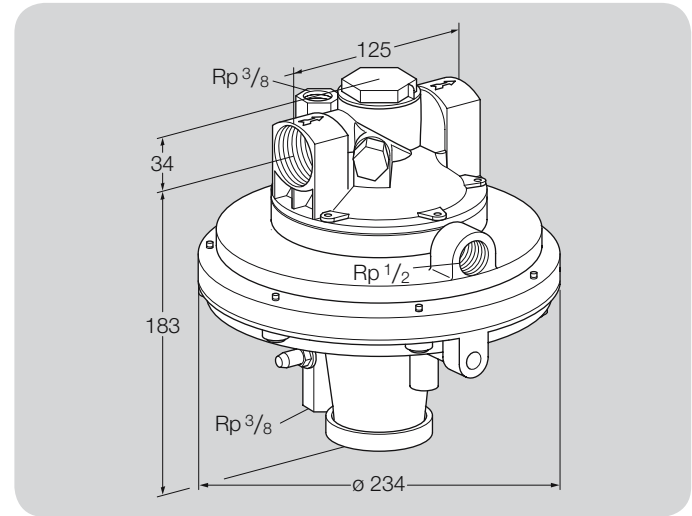

---

## 8 Maintenance cycles

At least once a year, at least twice a year in the case of biologically produced methane.

## Feedback

Finally, we are offering you the opportunity to assess this "Technical Information (TI)" and to give us your opinion, so that we can improve our documents further and suit them to your needs.

### Clarity

Found information quickly  
Searched for a long time  
Didn't find information  
What is missing?  
No answer

### Comprehension

Coherent  
Too complicated  
No answer

### Scope

Too little  
Sufficient  
Too wide  
No answer



### Use

To get to know the product  
To choose a product  
Planning  
To look for information

### Navigation

I can find my way around  
I got "lost"  
No answer

### My scope of functions

Technical department  
Sales  
No answer

### Remarks

(Adobe Reader 7 or higher required)  
[www.adobe.com](http://www.adobe.com)



## Contact

Elster GmbH  
Postfach 2809 · 49018 Osnabrück  
Strothweg 1 · 49504 Lotte (Büren)  
Germany  
T +49 541 1214-0  
F +49 541 1214-370  
[info@kromschroeder.com](mailto:info@kromschroeder.com)  
[www.kromschroeder.com](http://www.kromschroeder.com)

The current addresses of our international agents are available on the Internet:  
[www.kromschroeder.de/index.php?id=718&L=1](http://www.kromschroeder.de/index.php?id=718&L=1)

We reserve the right to make technical modifications in the interests of progress.  
Copyright © 2012 Elster GmbH  
All rights reserved.