

ECLIPSE AIR HEAT BURNERS

Dimensions—Series "RAH"

Data 142-1

11/93

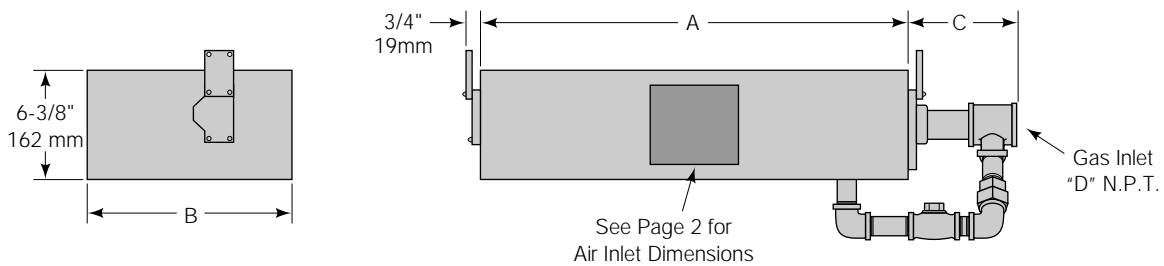

U.S. Reissue Pat. No. 26,244
Canadian Pat. No. 743,782

English Units

Burner Cat. No.	Assy. No.	Total Input (MM Btu/Hr.)		Blower Cat. No.*	Dimensions In Inches				Cross Sect. Area Sq. In.	Approx. Ship Wt. Lbs.
		0.8 MM Btu/Ft.	1.0 MM Btu/Ft.		A	B	C	D		
40 RAH	109036	0.4	0.5	54-54S-1/3	6-1/8	10-9/16	9-3/8	2	39	49
80 RAH	109269	0.8	1.0	54-54S-1/3	12-1/8	10-9/16	9-3/8	2	77	63
120 RAH	109270	1.2	1.5	54-54S-1/3	18-1/8	10-9/16	9-1/2	2	116	77
160 RAH	109271	1.6	2.0	65-84S-1/3	24-1/8	12-5/16	9-1/2	2	154	91
200 RAH	109272	2.0	2.5	66-94S-3/4	30-1/8	12-5/16	9-1/2	2	192	105
240 RAH	109273	2.4	3.0	66-94S-3/4	36-1/8	12-5/16	9-1/2	2	230	126
280 RAH	109274	2.8	3.5	66-94S-3/4	42-1/8	12-5/16	9-7/8	2	269	144
320 RAH	109275	3.2	4.0	66-94S-1	48-1/8	12-5/16	9-7/8	2	307	172
360 RAH	109276	3.6	4.5	67-115S-1-1/2	54-1/8	15-13/16	9-7/8	2	345	180
400 RAH	109277	4.0	5.0	67-115S-1-1/2	60-1/8	15-13/16	9-7/8	2	383	204
440 RAH	109278	4.4	5.5	67-115S-1-1/2	66-1/8	15-13/16	10-1/2	3	422	222
480 RAH	109279	4.8	6.0	67-115S-1-1/2	72-1/8	15-13/16	10-1/2	3	460	258
520 RAH	109280	5.2	6.5	67-115S-2	78-1/8	15-13/16	10-1/2	3	498	300
560 RAH	109281	5.6	7.0	67-115S-2	84-1/8	15-13/16	10-1/2	3	536	324
600 RAH	109282	6.0	7.5	67-115S-2	90-1/8	15-13/16	11	3	575	360
640 RAH	109283	6.4	8.0	67-115S-2	96-1/8	15-13/16	11	3	613	372

Metric Units

Burner Cat. No.	Assy. No.	Total Input kW		Blower Cat. No.*	Dimensions In Millimeters				Cross Sect. Area Sq. Cm.	Approx. Ship Wt. Kgs.
		769 kW/M	962 kW/M		A	B	C	D		
40 RAH	109036	117	147	54-54S-1/3	156	268	238	2"	252	22
80 RAH	109269	234	293	54-54S-1/3	308	268	238	2"	497	29
120 RAH	109270	352	440	54-54S-1/3	460	268	241	2"	748	35
160 RAH	109271	469	586	65-84S-1/3	613	313	241	2"	994	41
200 RAH	109272	586	733	66-94S-3/4	765	313	241	2"	1239	48
240 RAH	109273	703	879	66-94S-3/4	918	313	241	2"	1484	57
280 RAH	109274	821	1026	66-94S-3/4	1070	313	251	2"	1736	65
320 RAH	109275	938	1172	66-94S-1	1222	313	251	2"	1981	78
360 RAH	109276	1055	1319	67-115S-1-1/2	1375	402	251	2"	2226	82
400 RAH	109277	1172	1466	67-115S-1-1/2	1527	402	251	2"	2471	93
440 RAH	109278	1290	1612	67-115S-1-1/2	1680	402	267	3"	2723	101
480 RAH	109279	1407	1759	67-115S-1-1/2	1832	402	267	3"	2968	117
520 RAH	109280	1524	1905	67-115S-2	1984	402	267	3"	3213	136
560 RAH	109281	1641	2052	67-115S-2	2137	402	267	3"	3458	147
600 RAH	109282	1759	2198	67-115S-2	2289	402	279	3"	3710	163
640 RAH	109283	1876	2345	67-115S-2	2442	402	279	3"	3955	169

* Blowers listed are satisfactory for duct pressures from -0.5" w.c. to +0.2" w.c. (-1.2 mbar to +0.5 mbar). For other conditions, see Data 140-5 for blower details and sizing.



ECLIPSE COMBUSTION

Air Inlet Dimensions

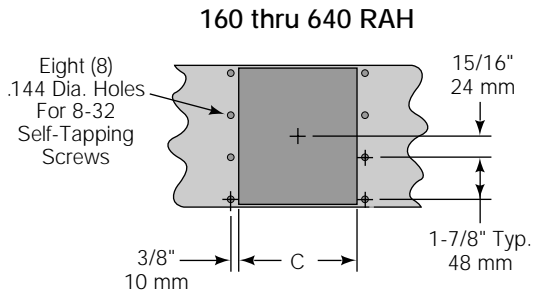
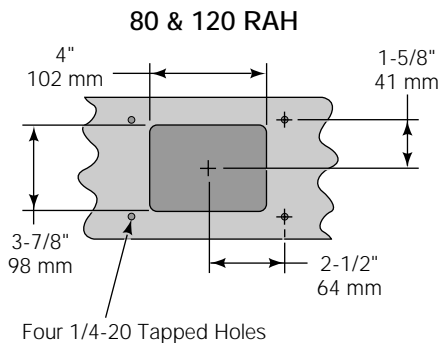

Burner Cat. No.	Dimension "C"	
	Inches	mm
40 RAH *	6	152
160 RAH	6	152
200 RAH	7-1/2	191
240 RAH	9	229
280 RAH	10-1/2	267
320 RAH	12	305
360 RAH	13-1/2	343
400 RAH	15	381
440 RAH	16-1/2	419
480 RAH	18	457
520 RAH	19-1/2	495
560 RAH	21	533
600 RAH	22-1/2	572
640 RAH	24	610

* The entire back of the 40 RAH is open for attaching the air manifold.

Pilot Components & Dimensions

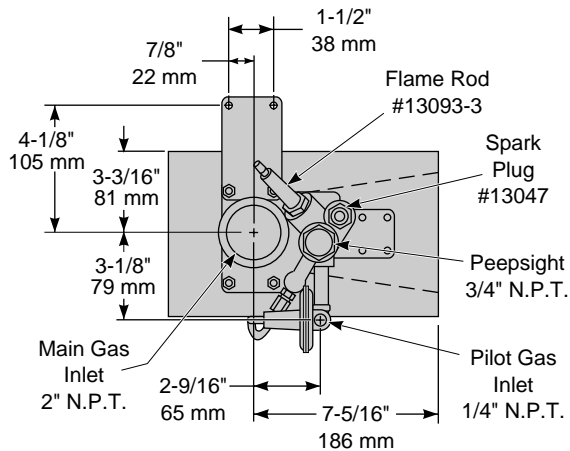
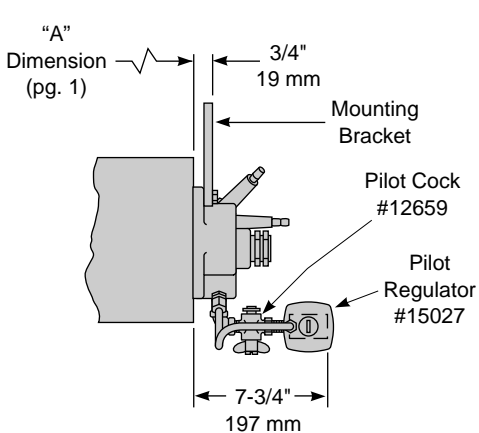

Check Valve Assembly Numbers

Burner	Assy.	N.P.T.
40 & 80 RAH	550088	1/2"
120 & 160 RAH	550092	3/4"
200 & 240 RAH	550096	1"
280 thru 400 RAH	550100	1-1/4"
440 thru 640 RAH	550104	1-1/2"



ECLIPSE COMBUSTION